



# All-in-One Walking Trainer

User manual



This manual should always be in close proximity of the product

# Table of content

<b>1. Symbols used in this manual</b> .....	<b>4</b>
<b>2. General safety</b> .....	<b>4</b>
2.1 Product Unit label .....	6
<b>3. General requirements</b> .....	<b>7</b>
3.1 Product information .....	7
3.2 Product description .....	7
3.3 Intended purpose .....	7
3.4 Intended population.....	8
3.5 Intended operator .....	8
3.6 Essential performance .....	8
3.7 Basic safety .....	8
3.8 Nonclinical functions .....	8
3.9 Product dimensions.....	8
<b>4. Instructions for use</b> .....	<b>10</b>
4.1 Installation of product.....	10
4.2 Installation of lifting unit and hand support .....	11
4.3 Operating the product .....	12
4.3.1 Operating instructions.....	12
4.3.2 Emergency situation .....	13
4.3.3 Stability function .....	14
4.4 Recharging the battery .....	15
4.5 Safety function, lifting motor .....	15
4.6 Safety function, control unit .....	15
4.7 Emergency lowering .....	16
4.8 Brakes.....	16
4.9 Size guide for Domino slings .....	17
4.9.1 Size information .....	17
4.9.2 Dimensions for slings .....	17
4.10 Transfer – walking trainer .....	18
4.10.1 Lifting from chair/wheelchair.....	18
4.10.2 Using the walking trainer .....	19
4.10.3 Placing in chair/wheelchair.....	19
4.11 Height adjustment of hand support.....	20
4.12 Electrical component diagram .....	20
<b>5. Troubleshooting</b> .....	<b>21</b>
<b>6. Cleaning</b> .....	<b>21</b>
<b>7. Maintenance</b> .....	<b>22</b>
7.1 Periodic maintenance .....	22
7.2 Daily check.....	22
7.3 Monthly maintenance.....	22
7.4 Yearly inspection .....	23
7.5 Maintenance report mechanical parts .....	24
7.6 Maintenance report actuator/lifting motor .....	25

7.7	Lifetime of actuator/lifting motor.....	26
7.7.1	Table to determine an actuators lifetime.....	26
<b>8.</b>	<b>Component part list.....</b>	<b>27</b>
8.1	Spare parts.....	27
<b>9.</b>	<b>Environmental protection .....</b>	<b>28</b>
<b>10.</b>	<b>Electromagnetic compatibility .....</b>	<b>28</b>
10.1	Suitable Environments .....	28
10.2	Cables .....	28
10.3	RF portable equipment.....	28
<b>11.</b>	<b>Complaints .....</b>	<b>29</b>

# 1. Symbols used in this manual

<b>Warning Symbol</b> Indication of potentially hazardous situation. If not avoided, it can result in serious injury or death.	
<b>Caution Symbol</b> Indication of potentially hazardous situation which may result in minor or moderate injury. It may also be used to alert against unsafe practices.	
<b>Notification Symbol</b> This symbol is used to notify correct use and handling of the product.	

# 2. General safety

	<p>This manual must be read and understood before use. Always keep this manual in close proximity of the product.</p> <p>The use, installation and service of this product must be in compliance with this manual to avoid accidents and serious personal injury.</p> <p>Never use or handle this product in other ways specified in this manual as it can result in personal safety hazards and/or cause damage to the product.</p> <p>Persons installing and/or using this product either as operator or user should have the necessary safety information and access to this manual.</p> <p>If the supply cord is damaged, it must be replaced by the manufacturer, its service agent or similarly qualified designated persons in order to avoid a hazard.</p>
--	--



Do not perform repairs, disassembly or assembly operations, add-ons, re-adjustments or modification of the product beyond what is described in this manual. These must be carried out by Ropox or Ropox authorized personnel. Do not perform service while in use.

This appliance can be used by children aged from 8 years and above and persons with reduced physical, sensory or mental capabilities or lack of experience and knowledge if they have been given supervision or instruction concerning use of the appliance in a safe way and understand the hazards involved. Children shall not play with the appliance. Cleaning and user maintenance shall not be made by children without supervision.

Do not use the product if it has defects or have become damaged before being repaired or replaced.  
If the control box makes unusual noise or smells, switch off the mains voltage immediately.

Take care that the cables are not damaged.

Unplug the mains cable on mobile equipment before it is moved.

The products must only be used in an environment that corresponds to their IP protection.



The information in this manual is based on correct installation in accordance with installation instructions for this product.

Ropox cannot be held liable if the product is used in any way that differs from stated in this manual and/or installation instruction.

Ropox reserve the right to amend this manual and reference documents without prior notice.

## 2.1 Product Unit label



	This product is CE-marked in accordance with: European Medical Device Regulation (EU)2017/745 Council Directive 2011/65/EU, RoHS
	Manufacturer name and address
	Date of production
<b>REF</b>	Stock number
<b>SN</b>	Serial number
	Consult manual before use
	Operating interval of electrically operated equipment. The use of electrical height adjustable equipment can run at maximum 2 minutes, followed by an 18-minute break.
	Type B applied part. The product complies with IEC 60601-1 requirements to provide protection against electric shock.
	Consult manual for important safety related information, warnings and safety precautions.
	Class II, double isolated electrical components.
	Do not dispose as unsorted municipal waste. Product must be returned to a designated recycling station.
	Mobile phones or other portable RF emitting equipment should be no closer to the product than 30cm.
	Operating and storing temperatures may not exceed 5-40°C
	Consult manual before use

## 3. General requirements

### 3.1 Product information

<b>Manufacturer:</b>	Ropox A/S Ringstedgade 221, DK-4700 Naestved +45 55 75 05 00 <a href="mailto:Info@ropox.com">Info@ropox.com</a>			
<b>Product models</b>	<b>Part number</b>	<b>Model</b>	<b>Configuration</b>	<b>UDI</b>
	25-20035-8 25-20526-8	Walking trainer 150kg Walking trainer 200kg	Convertible Convertible	57075810810S6 57075810811S8
<b>MDR Class 2017/745</b>  <b>MDD Class 93/68/EEC</b>	<b>Class I</b>			
<b>Applied part classification 60601-1</b>	<b>Type B</b> applied part			
<b>MEE Class 60601-1</b>	<b>Class II</b>			
<b>Intended environments</b>	This product is to be used only in:  Professional Healthcare Environment Homecare Environment  <i>The device is not intended for use in special environments as defined by IEC 60601-1-2</i>			
<b>Maximum user weight according to DS/EN 10535:2007</b>	150 / 200kg			
<b>Power supply</b>	100-240V ~50/60Hz			
<b>I in</b>	Max 2.5A			
<b>Intermittence</b>	2min use / 18min pause			
<b>Height adjustment</b>	150-190cm			
<b>Speed of actuation</b>	≈ 15mm/s			
<b>Number of lifts per charge (up and down)</b>	150kg = Approx. 100 200kg = Approx. 75			
<b>IP rating</b>	IPX4			
<b>Ambient temperature range</b>	-5 °C to +40 °C Transport and storage +5 °C to +40 °C Operation			
<b>Relative humidity:</b>	20% to 80% - non-condensing			
<b>Materials in contact with patient</b>	Sling	Polyester		
	Spreader bar	St37 tube construction with powder coating		

<b>Accessories</b>	
<i>Item Number</i>	<i>Model/specification</i>
25-20135-8	Walking Trainer kit

### 3.2 Product description

The All-in-One walking trainer system is a mobile personal lifter for people with limited mobility who need help with walking training. The medical staff, using different slings, can lift people up to 150/200 kg, depending on the chosen variant of lift.

### 3.3 Intended purpose

The product is used in situations where a patient must be lifted from a sitting position and up to a standing position. The product must not be used for patient transport. The product must always be used with Ropox suitable lifting slings.

### 3.4 Intended population

Patients with mobility difficulties.

### 3.5 Intended operator

Intended operator must have relevant health professional training before using the product, as well as have read and understood this guide. Children, patient, or lay person is not considered a suitable operator.

### 3.6 Essential performance

The lifting motor has a mechanical emergency lowering facility. In case of failure of electronics during use, this can be used to lower the patient to a safe height.

### 3.7 Basic safety

The battery must always be checked for capacity before starting work. An audible warning will sound if the battery capacity is too low. The product is equipped with an emergency stop, its function must also be checked before use.

### 3.8 Nonclinical functions

The product has no clinical effect. This is a patient lifter.

### 3.9 Product dimensions

	25-20035	25-20526
	150kg	200kg
Lifting capacity	150 kg	200 kg
Min. lifting height, lifting hook	150 cm	150 cm
Max. lifting height, lifting hook	190 cm	190 cm
Lifting travel	40 cm	40 cm
Min. height of handle	75 cm	75 cm
Max. height of handle	105 cm	105 cm
Width of handle	65 cm	65 cm
Length of undercarriage	117 cm	122 cm
Length legs	97 cm	98 cm
Min. inside distance between legs	50 cm	54 cm
Max. inside distance between legs	94 cm	118 cm
Min. outside distance between legs	65 cm	69 cm
Max. outside distance between legs	109 cm	133 cm
Height of undercarriage	12 cm	12 cm
Free height under legs	7 cm	7 cm
Wheel diameter	100/75 mm	100/75 mm
Turning circle	125 cm	131 cm
<b><u>Weight</u></b>		
Weight of spreader bar (lifting unit)	5.0kg	5.0 kg
Weight of handle unit	8.5 kg	8.5 kg
Weight of battery	3.0 kg	3.0 kg
Total weight	55.0 kg	61.5 kg
Approx. number of lifting operations per charging	100	75

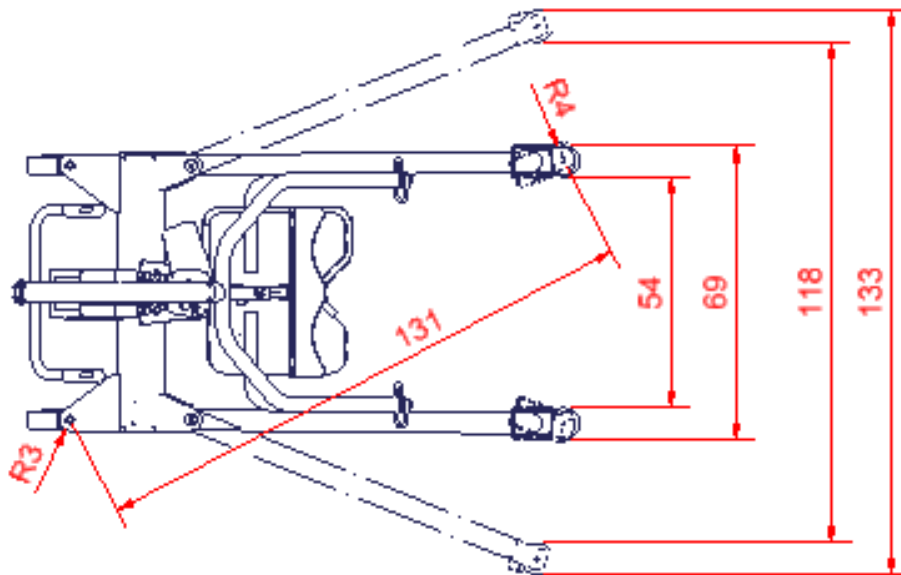
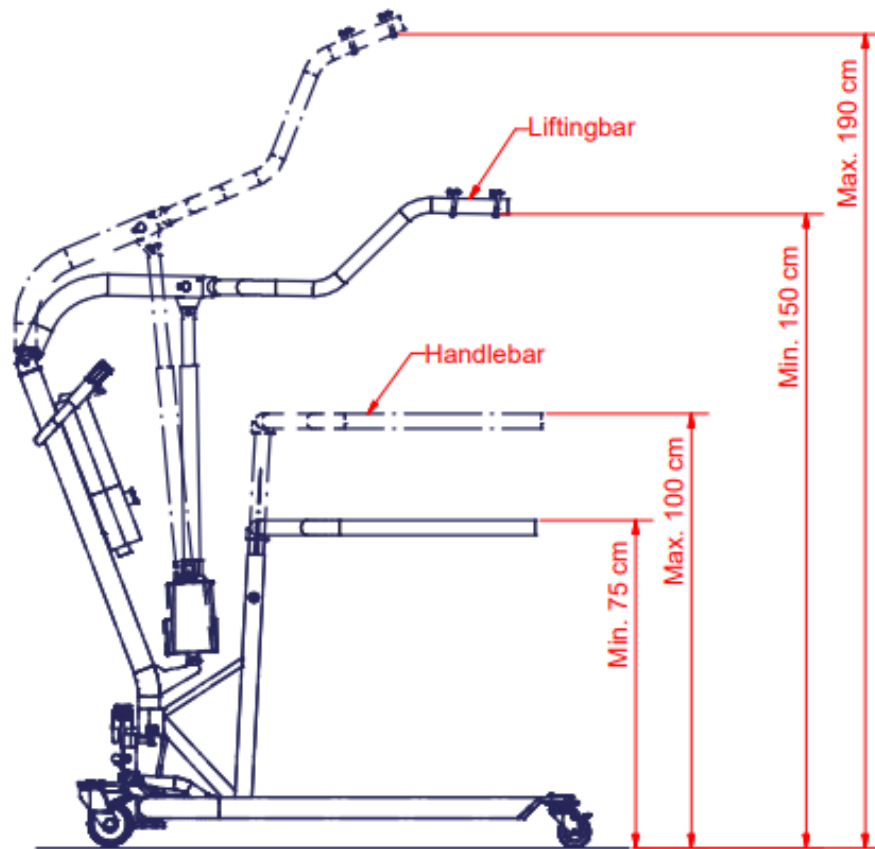

	<p><b>Note!</b> Dimensions in centimeters.</p>
--	--

## 4. Instructions for use

### 4.1 Installation of product

1. Place the lifting mast in the mast holder of the frame. Tighten the two screws with the 5mm Insex wrench provided and use locking nut on opposite site.
2. Connect the cable from the leg spreading motor to the control unit in output terminal 2, see section 4.12 "Electrical component diagram".

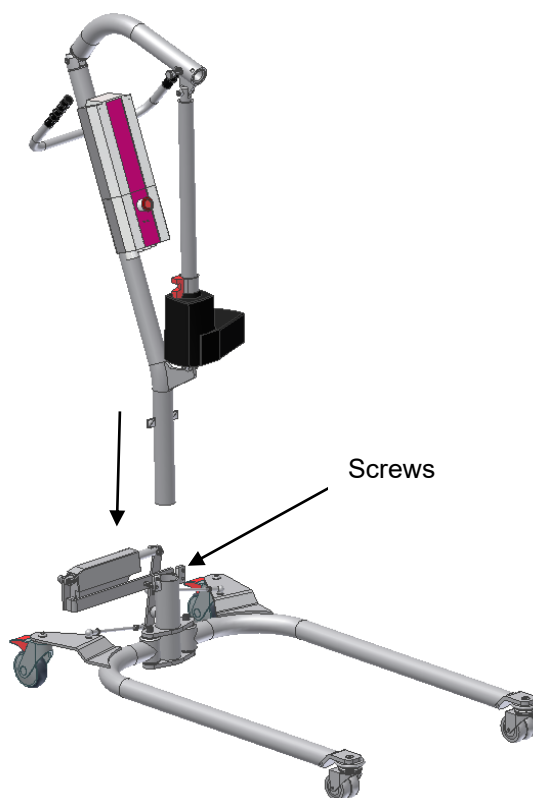
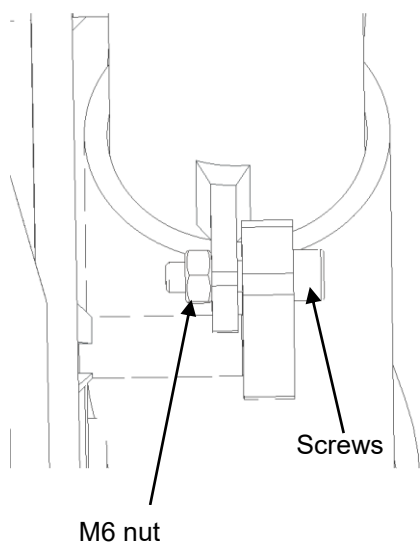

#### Note!

Assembly of 150kg and 200kg Walking Trainers is identical. Only difference is the undercarriage.

## 4.2 Installation of lifting unit and hand support

1. Brake the rear wheels.
2. Hold the lifting unit (turn it through 90°) so that the locking pin may be pushed into the corresponding slide rail of the lifting mast.
3. Push in the lifting unit.
4. Now turn it 90° clockwise until a click is heard from the locking screw.
5. Check that the arm has been properly locked.
6. Hook the hand support on to the mast holder.
7. Tighten the tightening handle on the side.
8. The walking trainer is now ready for use.

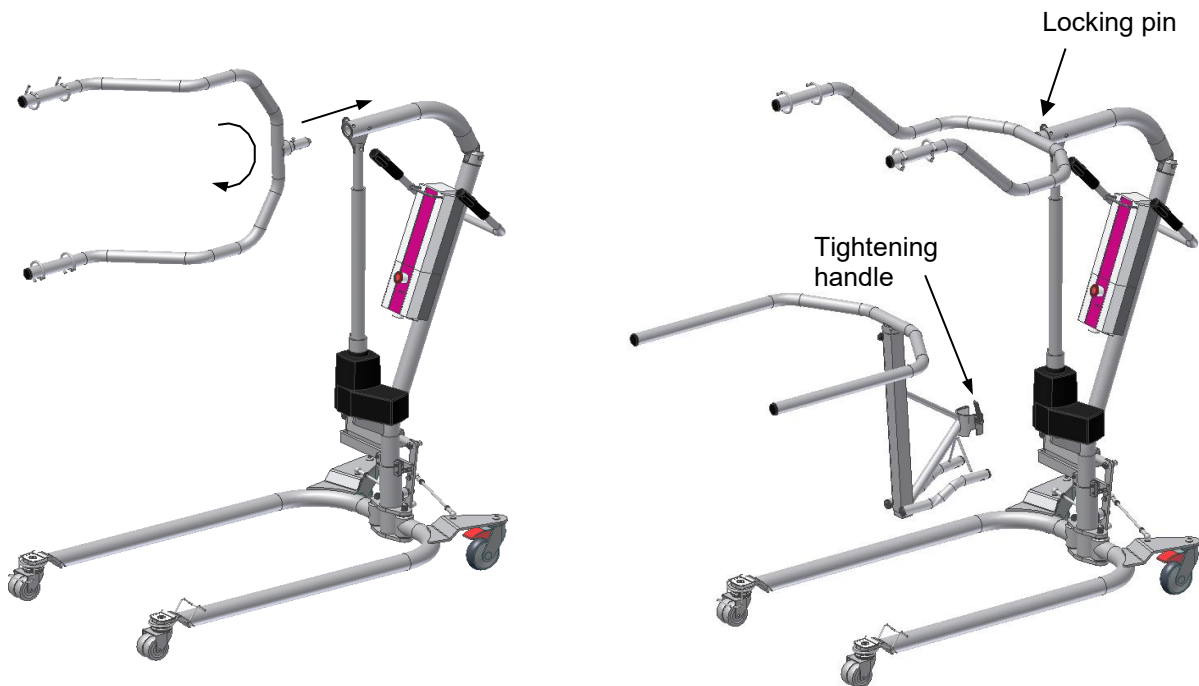

## Dismounting

1. Brake the rear wheels.
2. Loosen the tightening handle.
3. **Note!** Do not unscrew it completely.
4. Lift the hand support off the mast holder.
5. **Note!** It may be stuck owing to the clamping plates.
6. Pull the locking screw while turning the spreader bar 90° counter-clockwise.
7. The lifting unit may now be pulled out.

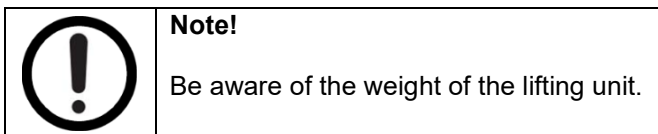

## Mounting of directional steering of the front wheels

1. Dismount the M10x45 countersunk screw with washer and nut keeping the wheel in place.
2. Mount plate and holder for steering using the new M10x50 countersunk screw.

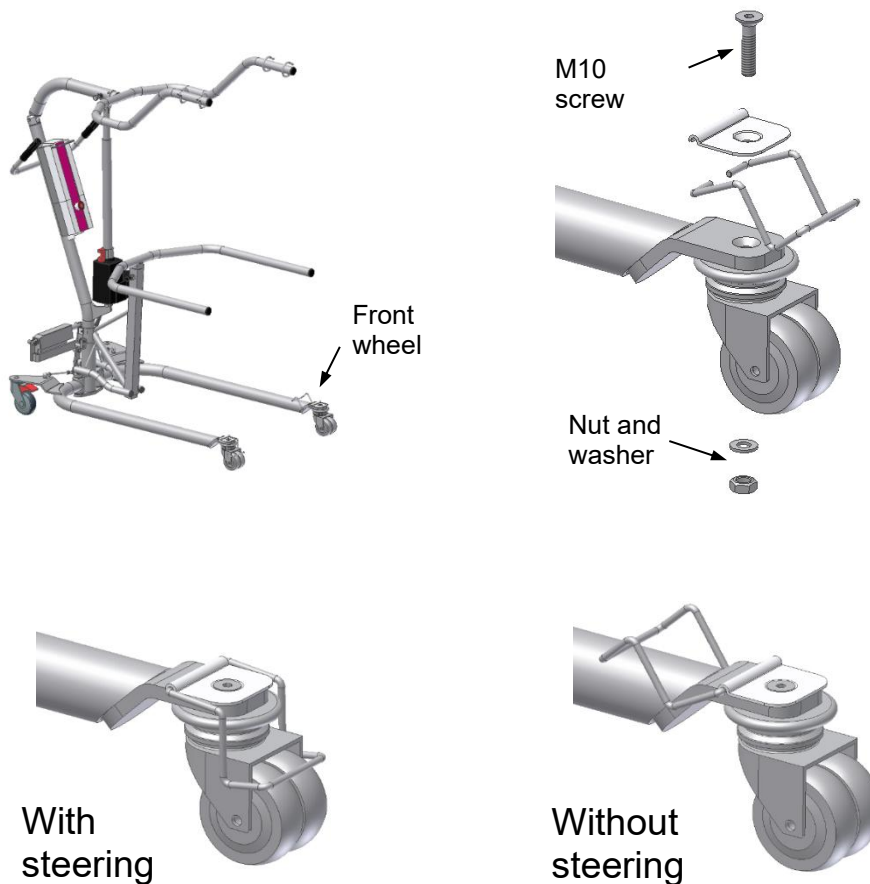

## 4.3 Operating the product

	<p><b>Note!</b></p> <p>It is important that you are familiar with the use of the hoist and its functions, and that it works properly. For the best possible safety, all users of the hoist must read this user manual before using the hoist.</p>
--	---

For the All-in-One you can use any of Ropox Domino slings.

### 4.3.1 Operating instructions

- Check that the emergency stop has been released. If not, turn the button clockwise until release.
- The hoist is operated by means of the hand control unit. The two upper buttons control the lifting/lowering movement, whereas the two lower buttons control the leg spreading facility. It is not possible to use two functions simultaneously.
- Check that the sling provided is correct for the lifting operation to be performed. This applies to size as well as shape. Further information about the choice of slings will be found in "Domino Slings User manual".
- The battery should be recharged regularly, to ensure that the hoist is always available (e.g. every night).

	<p><b>Note!</b></p> <p>In case of erroneous operation of the hand control unit (e.g. too quick change of direction) the hoist does not react. Let go of the push button – wait a few seconds and press again.</p>
--	---

**Warning!**

The product should always be able to travel the full range of actuation without colliding with objects. Failing to do so will compromise the product stability.  
Special care should be taken in ensuring that no children or adults are sited under the product as severer injury from entrapment may occur.

#### 4.3.2 Emergency situation

Emergency stop and emergency lowering (electrical and mechanical) should be used in emergencies only. Should it be necessary to activate the emergency functions, contact the distributor before using the hoist again.

### 4.3.3 Stability function

The lift has a leg spreading function, which is designed to increase the stability of the lift during lifting of a patient. While parallel, the legs have a minimum inside distance between each other of 50cm or 54cm, depending on lifting capacity, but can be increased to 94cm or 118cm. This allows the lift to get as close as possible to a person in a wheelchair.

It is IMPORTANT that during lifting of a patient, that the legs are spread out as much as possible, as you might otherwise risk the lift having reduced stability.

This is not applicable to transporting a patient in the lift, in which case you'd like the legs to be parallel, to be able to get in through doors and be free of obstacles.

150kg

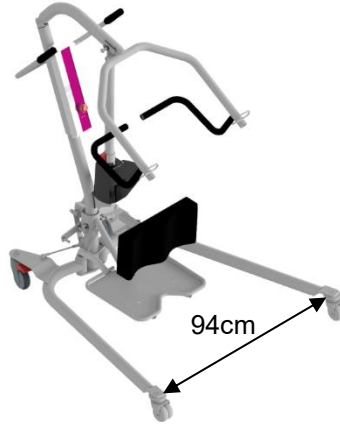
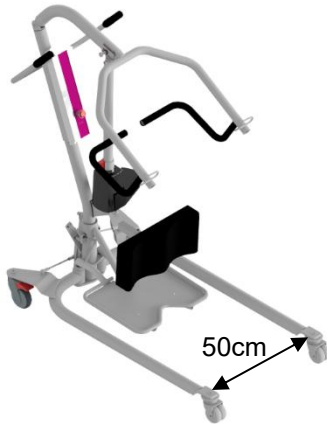

200kg

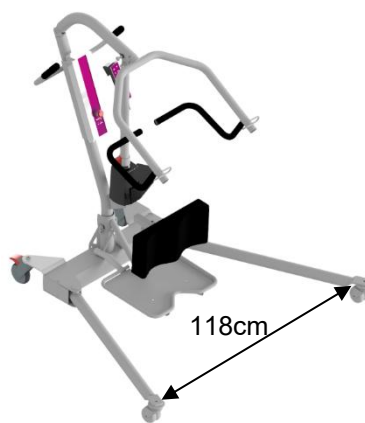
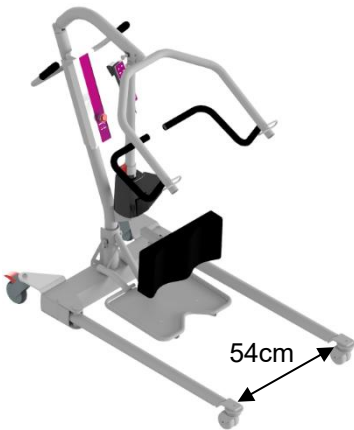

The leg spreading function is controlled with the same remote as the lifting arm.



**Warning!**

The legs must be spread out during lifting of a patient to or from a seated or lying position!

#### 4.4 Recharging the battery

- The battery **must** be recharged after approx. 35/50 lifting operations, depending on lifting capacity – i.e. at 50% battery capacity. In case of continued use you will hear an acoustic signal. The battery can still be used, but it will affect its recharging capability.
- We recommend charging as soon as the hoist is not being used for a longer period of time, e.g. every night. The battery cannot be over-charged and it is only "healthy" for the battery to be recharged often as it increases the battery life.
- Charging is made directly in the control unit by means of the mains cable provided. Insert the cable into the wall outlet and the control unit, see section 4.12, and switch on power. The hoist cannot be used when connected to mains voltage.
- A green light on the control unit indicates connection to mains voltage. A yellow light indicates that the battery is being recharged.
- When the battery has been fully charged, the yellow light will be out.
- Full recharging takes 4-5 hours.
- If charging is made via a wall-mounted charging station (optional) a battery may be constantly charged in the station. The batteries may be easily switched by means of the snap system on top of the battery box.



#### Note!

Make sure that the plug from the battery is correctly inserted in the control box, if the plug has been pulled out, before using the lift again.



#### 4.5 Safety function, lifting motor

The lifting motor is provided with a safety function, spline, against jamming. If the lifting arm meets with resistance during lowering, the movement of the arm will stop automatically. Thus, a person cannot get jammed between the lifting arm and the bed.

#### 4.6 Safety function, control unit

- Protective motor switch for lifting and leg spreading, protecting against overloading
- Short-circuit protection
- Acoustic signal sounding when the batteries need charging
- Electrical emergency lowering if the hand control unit does not work
- Built-in charger



#### Warning!

Owing to the safety function on the motor the lifting arm and spreader bar may fall freely to the spindle of the motor. Therefore, make sure that the lifting arm does not "hang", that is has always been pressed down to ensure that it rests on the spindle of the motor before and after all lifting operations. This is important as otherwise an injury may result if the lifting arm "falls" down.

### Emergency stop

If the hoist is to be stopped owing to an emergency – press the red button on the control unit. When the button has been depressed the electrical functions of the hoist cannot be activated and the battery indicator has been switched off.

## 4.7 Emergency lowering

If the hoist is to be lowered and the hand control unit does not work, there are two possible solutions:

- The electrical emergency lowering of the control unit (marked emergency), see section 4.12. Press with a ball pencil or the like and the person will be lowered slowly.
- The mechanical emergency lowering of the lifting motor. Pull up the red handle, see drawing.

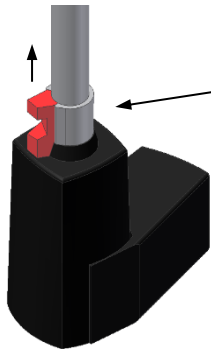

The lifting motor has a mechanical emergency lowering facility. To release it, pull the red handle.

## 4.8 Brakes

The hoist may be braked on the two large rear wheels. Press down the rear part of the brake with the foot to brake the hoist. Release the brake by pressing the front part of the brake with the foot.

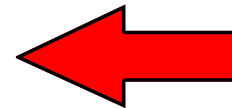
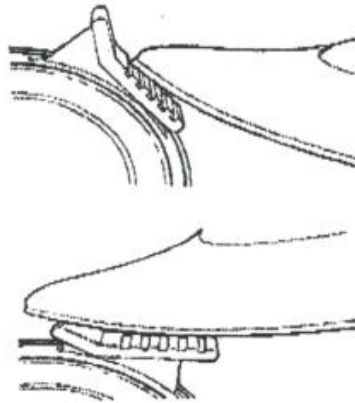

Brake

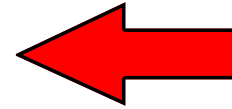

Release





### Note!

Never brake the hoist during lifting except when used in stand-up mode.

## 4.9 Size guide for Domino slings

In choosing the correct sling to use, the “Facts-Label” on the sling can be used. Alternatively, the following instructions can be used. This section can also be used to determine which slings to choose, when acquiring the product. It's recommended to use the Domino slings exclusively with the Ropox All-in-One hoist.

### 4.9.1 Size information

Type	Walking Trainer Slings		
Height	145 – 175cm	165 – 185cm	175 – 195cm
Weight	40 – 60kg	60 – 80kg	80 – 100kg
Size	 Small	 Medium	 Large

### 4.9.2 Dimensions for slings

The walking trainer slings come in three different sizes. For these, the waist size (W) is provided in order to, together with height and weight, choose the best sling for the patient. The waist size is indicated as the **maximum size**. The dimensions are as follows:

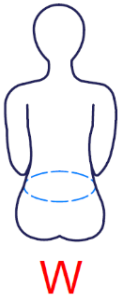

Type	Size	W
Walking Trainer Slings	<u>Small</u>	90 cm
	Medium	110 cm
	Large	125 cm

## 4.10 Transfer – walking trainer

- Before lifting a person, it is important to be familiar with the walking trainer and that it works satisfactorily.
- Also, it is important to choose the right size of sling for the lifting operation to be performed. Further information about the use of slings will be found in the "Walking Trainer Manual for Slings".
- We recommend that the walking training take place on a horizontal surface. However, the walking trainer may be used on surfaces with gradients up to 5°.
- Only brake the hoist when it is parked or standing on a sloping surface, e.g. in bathrooms.
- Beds or wheelchairs, which the client may be transferred from, must be locked in place during lifting.
- Never lift a person higher than necessary.
- Always be aware the maximum load of the hoist.-

**Before lifting a client, try the hoist yourself.**

**Risk assessment shall be carried out to ensure that the correct size, type, and shape of slings is being used for the patient**

### 4.10.1 Lifting from chair/wheelchair

1. Place the sling around the client sitting in the chair/wheelchair. Close the body belt and tighten it so that it is still comfortable.
2. Place the leg straps between the thighs and pull the lifting straps placed in front of the shoulders through the black loops of the leg straps. Make sure that the four grey lifting straps are in the same height before attaching them to the spreader bar.
3. **Increase the width between the legs** of the hoist and move it towards the client.
4. Place the feet of the client on the floor.
5. Move the hoist so close to the client as possible.
6. Make sure that the spreader bar is in the lower position.
7. Place the lifting straps of the sling correctly in the hooks of the spreader bar. Check that all straps have been fitted correctly.
8. Lift the client a few centimeters above the seat - STOP – and make sure that the sling is placed correctly.
9. When the client is comfortable, lift him/her from the chair to standing position.
10. Slowly pull the hoist away from the chair - STOP – adjust the sling and lifting height until the client is standing comfortably.
11. You may now start walking training.



**Note!**

The wheelchair must be braked during transfer to and from the chair.

#### 4.10.2 Using the walking trainer

- The carer may walk in front of or beside the walking trainer, instructing or supporting the client.
- Raising or lowering the sling frame will relieve the client depending on the phase of walking training.
- Use the hand support to begin with in order to give the client something to hold on to and to use for pushing/steering.



- During the last phase of the walking training the client may use the hand support only without the support of the sling.
- The steering devices of the two front wheels contribute to steering the walking trainer, e.g., when persons with hemiplegia start walking training.

#### 4.10.3 Placing in chair/wheelchair

To place a person in a chair/wheelchair, do the following procedures:

1. **Increase the width between the legs** of the walking trainer and move it to the chair.
2. Make sure that the client is positioned correctly above the chair and lower the hoist slowly.
3. Check that the client is positioned correctly during the entire operation.
4. When assisting a client in getting back into the chair, lower the client so that he/she just touches the chair.
5. If the chair can be tilted a little backward it is easier to place the client correctly.
6. If two assistants are present, one may press gently on the knees of the client.

### 4.11 Height adjustment of hand support

Press the red button, then pull locking tap. Hand support can now be pulled upwards or pushed downwards for adjustment of correct height for user.



### 4.12 Electrical component diagram

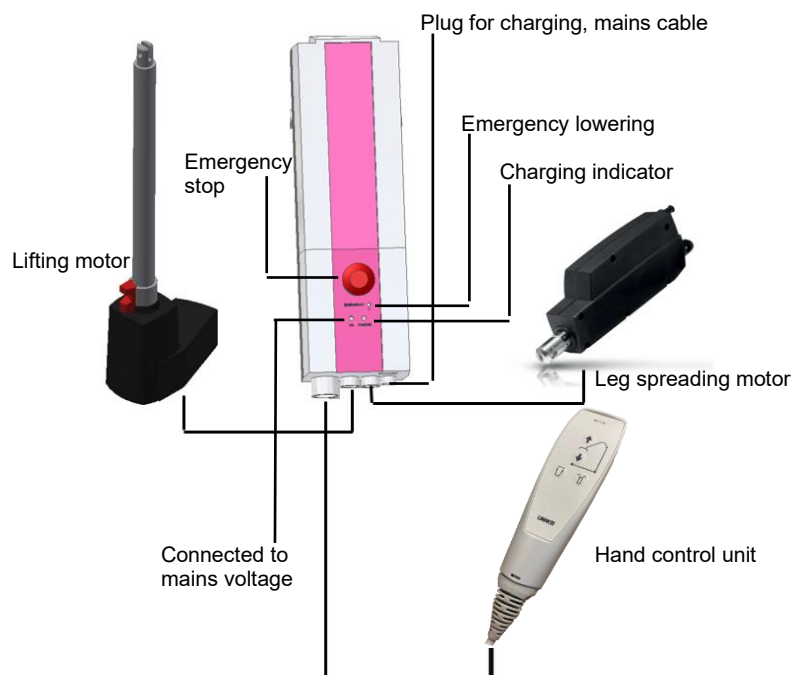

## 5. Troubleshooting

If the walking trainer does not work, check, and test the following procedures before contacting an authorized distributor.

- Has the battery been charged?
- Has the emergency stop been released?
- Have all plugs been inserted correctly?
- Does the hand control unit work properly and has it been mounted correctly?
- Try with another hand control unit or charger.
- If the lifting arm cannot be lowered by means of the hand control unit, use mechanical or electrical emergency lowering, and the lifting arm will come down.

Symptom	Possible cause	Action
Indicator for mains voltage does not light up	- Mains voltage not connected - Control unit defective	- Connect mains voltage - Replace the control unit
The motors do not start. A click is heard from the relays of the control unit	- The plug has not been correctly inserted into the control unit - Motor defective - Control unit defective	- Insert the motor plug correctly into the control unit - Replace the motor - Replace the control unit
The motors do not start. No click is heard from the relays of the control unit	- Control unit defective - Hand control unit defective	- Replace the control unit - Replace the hand control unit
The control unit is completely dead. No click is heard from the relays of the control unit	- Battery completely discharged - Battery defective	- Charge the battery - Replace the battery
The control unit is in order except for one direction of one channel	- Hand control unit defective - Control unit defective	- Replace the hand control unit - Replace the control unit

## 6. Cleaning

Clean the walking trainer with a damp cloth wrung in warm water with a mild detergent. Electrical components may be dried with a firmly wrung cloth. Do not use water directly on these components. Never use solvents.

	<b>Note!</b>
	<p>Do not use cleaning agents containing abrasive e.g. scouring powder, steel wool, scouring sponge.</p> <p>This product is not designed to be sterilized, autoclaving and sterilization beyond normal cleaning is may possibly change the product safety and function.</p>

### Preapproved cleaning agents

Trade name	Solution
Acticlör plus	1000ppm
S90 sanirens	1-3% peracid
FUTUR, Alkalisk rens	1% solution [pH 9,5]
Overfladedesinfektion	70% Ethanol
Suverent Universalrengöring	1% solution [pH 8]

# 7. Maintenance

**Note!**

Failing to comply with periodic maintenance may result of degrading of product function and safety.

## 7.1 Periodic maintenance

Always make sure that the mechanical and electrical systems of the hoist operate satisfactorily. In case of malfunction stop the hoist and check or repair it, as required. Malfunction may be a symptom of a defect, which may become worse and present a safety risk in critical situations. It is therefore important to check the hoist as described below.

## 7.2 Daily check

- Sling
1. Check that the slings are clean, if not, send them to the wash.
  2. Check for wear and that the seams are intact and not frayed. A worn sling must be replaced.
- Hoist
3. Check that the hand control unit works satisfactorily and is mounted correctly.
  4. Check that cables have been correctly inserted into the control unit.
  5. Check visually that shaft and bolted joints run smoothly and silently.
  6. Keep the hoist clean. A clean hoist is safer and has a longer life.

## 7.3 Monthly maintenance

- Sling
1. Inspect the slings carefully and replace them in case of visible defects or wear.
- Hoist
2. Check that hand control unit, control unit and battery have no visible defects.
  3. Check that cables have been inserted correctly and are undamaged.
  4. Check that the lifting motor is not bent and is undamaged.
  5. Check that all shaft and bolts joints are undamaged and stable. Worn parts should be replaced.
  6. Check that the wheels run smoothly. Clean them once a month.

## 7.4 Yearly inspection

Preventive service **must** be made once a year. Follow the procedures below must be followed.

### - Forms to service report

Take a copy off the forms on page 24 and 25 and use them when filling out the service report. We recommend scaling them up to A4 size.

### - Visual inspection

Inspect hoist frame and welds for wear, skews, or any other damage.

### - Testing

Check all functions with and without load.

Check emergency stop.

Check battery and charger.

### - Mechanical inspection, see also section 7.5

Inspect that all parts are moving freely and without any abnormal noise.

**Note!** Bolt M6x50 holding Spreader bar should be dismantled and inspected visually.

**Note!** Axle holding lifting arm should be dismantled and inspected visually .

Inspect, that bolts are tight.

### - Electric inspection, also see also section 7.6

Check actuator for damage, noise, and the fixtures.

Check the battery voltage with max load and a full lifting cycle. If below 19V the battery needs to be changed. Replace defective battery, if any.

Check wires for damage.

Check all plugs and sockets.

## 7.5 Maintenance report mechanical parts

Invoice address:		Delivery address:			
Repair	Mounting	Service		Warranty	
<b>Lift type:</b>		<b>Serial No.</b>			
<b>Inspection carried out</b>		<b>OK</b>	<b>Defective</b>	<b>Repaired</b>	<b>Replaced</b>
Lubrication of wheels					
Lubrication of load bearing shafts and hooks					
Welds					
Bolts / bushings					
Mast and arm connection					
Arm and lifting accessories					
Test of the leg-spreading function					
Switches and safety functions					
Test of batteries and recharging function					
Test of the seams of the Domino slings					
All bolts					
Lifting motor and leg-spreading motor. See separat pages regarding motors					
Other					
Functional test of the lift					
Consumption of spare parts					
<b>Spare part No:</b>		<b>Products:</b>			
<b>Comments:</b>					
<b>Milage:</b>		<b>Time consumption:</b>			
<b>Date:</b>		<b>Performed by:</b>			

## 7.6 Maintenance report actuator/lifting motor

Invoice address:		Delivery address:		
Repair	Mounting	Service	Warranty	
<b>Lift type:</b>		<b>Serial No.</b>		
<b>Inspection carried out</b>		<b>OK</b>	<b>Not OK</b>	<b>Remarks</b>
Powerconsumption without load				
Powerconsumption with max. load				
Noise				
Plastic				
Wires and cords				
Straightness and outbending when the actuator is completely out				
Looseness				
Fixing points				
Marks and dents				
Other				
Consumption of spare parts				
<b>Spare part No:</b>		<b>Products:</b>		
<b>Comments:</b>				
<b>Milage:</b>		<b>Time consumption:</b>		
<b>Date:</b>		<b>Performed by:</b>		

## 7.7 Lifetime of actuator/lifting motor

A service technician fills out the below points from the user information

How often is the lift used pr. day:

Actuators production date:

Expected changing of actuator:

### 7.7.1 Table to determine an actuators lifetime

**Note!!** The lifting actuator should be changed when it is max. 6 years or after 10.000 strokes.

Continue normal use

Consider changing

Actuator should be changed

Lifts pr. day	Age in years									
	1	2	3	4	5	6	7	8	9	10
1	365	730	1095	1460	1825	2190	2555	2920	3285	3650
2	730	1460	2190	2920	3650	4380	5110	5840	6570	7300
3	1095	2190	3285	4380	5475	6570	7665	8760	9855	10950
4	1460	2920	4380	5840	7300	8760	10220	11680	13140	14600
5	1825	3650	5475	7300	9125	10950	12775	14600	16425	18250
6	2190	4380	6570	8760	10950	13140	15330	17520	19710	21900
7	2555	5110	7665	10220	12775	15330	17885	20440	22995	25550
8	2920	5840	8760	11680	14600	17520	20440	23360	26280	29200
9	3285	6570	9855	13140	16425	19710	22995	26280	29565	32850
10	3650	7300	10950	14600	18250	21900	25550	29200	32850	36500
11	4015	8030	12045	16060	20075	24090	28105	32120	36135	40150
12	4380	8760	13140	17520	21900	26280	30660	35040	39420	43800
13	4745	9490	14235	18980	23725	28470	33215	37960	42705	47450
14	5110	10220	15330	20440	25550	30660	35770	40880	45990	51100
15	5475	10950	16425	21900	27375	32850	38325	43800	49275	54750
16	5840	11680	17520	23360	29200	35040	40880	46720	52560	58400
17	6205	12410	18615	24820	31025	37230	43435	49640	55845	62050
18	6570	13140	19710	26280	32850	39420	45990	52560	59130	65700
19	6935	13870	20805	27740	34675	41610	48545	55480	62415	69350
20	7300	14600	21900	29200	36500	43800	51100	58400	65700	73000
21	7665	15330	22995	30660	38325	45990	53655	61320	68985	76650
22	8030	16060	24090	32120	40150	48180	56210	64240	72270	80300
23	8395	16790	25185	33580	41975	50370	58765	67160	75555	83950
24	8760	17520	26280	35040	43800	52560	61320	70080	78840	87600
25	9125	18250	27375	36500	45625	54750	63875	73000	82125	91250
26	9490	18980	28470	37960	47450	56940	66430	75920	85410	94900
27	9855	19710	29565	39420	49275	59130	68985	78840	88695	98550
28	10220	20440	30660	40880	51100	61320	71540	81760	91980	102200
29	10585	21170	31755	42340	52925	63510	74095	84680	95265	105850

## 8. Component part list



### Note!

Ropox will make parts list and circuit diagrams available for extraordinary maintenance and repair beyond what is described in this manual. Repair beyond what is described in this manual may only be done by Ropox designated service personnel.

### 8.1 Spare parts

Position	Description	Number in product	Item no.
1	Battery	1	25*29030-002
2	Control box	1	150kg = 25*29020-002 200kg = 25*29530-001
3	Lifting motor	1	25-20235-9
4	Hand control unit	1	25-29050-9
5	Leg spreading motor	1	25-20212-9
6	Brake wheels	2	25-98202-9
7	Wheels	2	25*98212-002

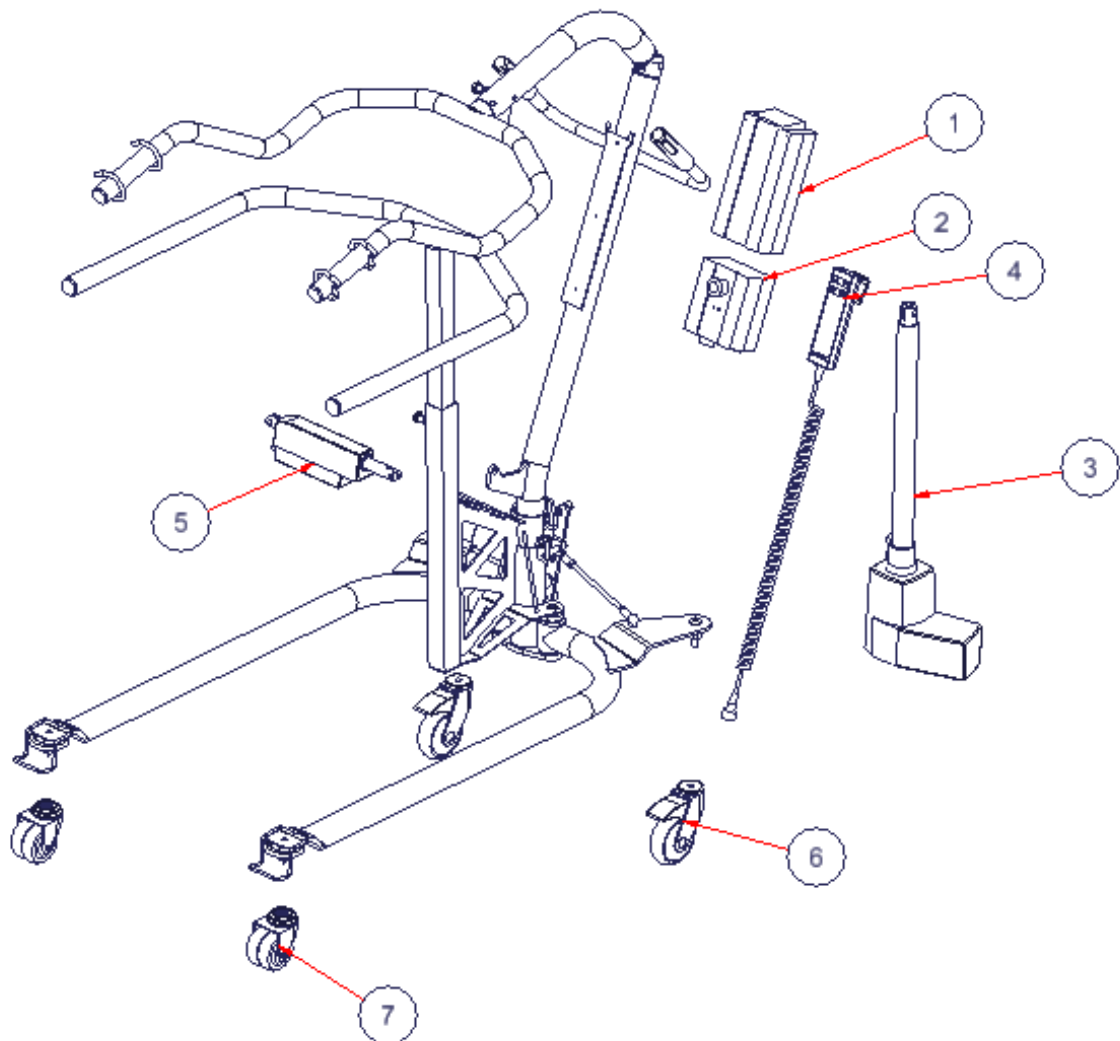

# 9. Environmental protection

The product is not intended to be disposed as municipal waste. Proper disassembly, sorting and disposal of components must be done by waste disposal professionals.



Part	Disposal recommendation
Control box	Electronics
Motors	Electronics
Handcontrol unit	Electronics
Battery	Electronics
Handle	Hard plastic
Frame	Steel waste
Wheel	Hard plastic

# 10. Electromagnetic compatibility

## 10.1 Suitable Environments

The device is suitable for use at home, at daycare centers, at day centers for persons with physical or mental disabilities or at hospitals except near active HF surgical equipment and the RF shielded room of a medical electrical system for magnetic resonance imaging, where the intensity of electromagnetic disturbances is high.

## 10.2 Cables

Cable component	Length
Hand control spiral cable	Approx. 2.4m extended.

	<p><b>Warning!</b></p> <p>Use of accessories, transducers and cables other than those specified or provided by the manufacturer of this could result in increased electromagnetic emissions or decreased electromagnetic immunity of this equipment and result in improper operation.</p>
--	---

## 10.3 RF portable equipment

	<p><b>Warning!</b></p> <p>Portable RF communications equipment (including peripherals such as antenna cables and external antennas) should be used no closer than 30 cm (12 inches) to any part of the device, including cables specified by the manufacturer. Otherwise, degradation of the performance of this equipment could result.</p>
--	--

# 11. Complaints

See our general terms of sale and delivery on [www.ropox.com](http://www.ropox.com)



**ROPOX A/S**

Ringstedgade 221  
DK – 4700 Næstved

Tel.: +45 55 75 05 00 Fax.: +45 55 75 05 50

E-mail: [info@ropox.dk](mailto:info@ropox.dk)

[www.ropox.dk](http://www.ropox.dk)