

4SingleManual

User Manual

Mounting Instructions

Keep this folder with product at all times!

Contents

1. INTRODUCTION	3
2. APPLICATION	3
3. CONFORMITY WITH EU DIRECTIVE AND UK DIRECTIVE.....	3
4. TECHNICAL DATA.....	4
5. SCHEMATIC DIAGRAM OF FRAME.....	5
6. MOUNTING INSTRUCTIONS, ILLUSTRATIONS	6
<i>6.1 Assembly of frame</i>	<i>7</i>
<i>6.2 Mounting of wheels (option).....</i>	<i>7</i>
7. LIST OF COMPONENTS.....	7
8. OPTIONS	9
9. SAFETY IN USE	9
10. CLEANING/ MAINTENANCE	10
<i>10.1 Cleaning of frame.....</i>	<i>10</i>
<i>10.2 Maintenance.....</i>	<i>10</i>
<i>10.3 Service schedule, operation and maintenance</i>	<i>11</i>
11. COMPLAINTS.....	12

1. Introduction

4Single is a multi-function table, which may be adjusted to suit seated or standing activities. Owing to the unique design there are a variety of applications and the table is therefore also ideal for wheelchair users.



This document must ALWAYS accompany the product and be read by and available to users.

All users must follow these instructions. It is very important that the instructions have been read and understood prior to operation of the product.

These instructions must always be available to the user and must accompany the product in case of relocation.

Correct use, operation and inspection are decisive factors for efficient and safe performance.



The operation must be made or supervised by an experienced adult, who has read and understood the importance of section 8 "Safety in use"

2. Application

4Single is designed to obtain optimum working height for the user. It is an activity table and not for use as a lifting table or person lifter.

The product must be used indoor, under room temperatures and humidity as stated in section 3. 4Single is not designed for use in damp rooms.

3. Conformity with EU Directive and UK Directive

This product has CE marking and is thus in accordance with the basic requirements concerning functionality and safety of the current EU Directive. See separate CE declaration.

This product has UKCA marking. See separate Declaration of Conformity

4. Technical data

Product:	4SingleManual
Item numbers:	Set of legs, manual
	Height 58-88cm / 22,8 – 34,6in H1 50-41110
	Height 65-95cm / 25,6 – 37,4 in H2 50-41210
	Height 78-108cm / 30,7 – 42,5 in H3 50-41870
	Height 78-108cm / 30,7 – 42,5 in H4 50-41875
	Front fascias for frame L = xxx cm 50-42xxx From 60-300cm in increments of 1cm From 23,6-118,1in in increments of 0,4in
	Side fascias for frame W = xxx cm 50-44xxx From 60-200cm in increments of 1cm From 23,6-78,7in in increments of 0,4in
Options:	Wheels: Increase the table height by 6.5cm / 2.5in
Material:	Welded steel tubes St. 37 and various plastic components
Surface treatment:	Blue chromate, powder coating: Standard CWS 81283 RAL 7021 mat
Max. load of frame:	150kg / 330lb evenly distributed
Temperature:	5-45° C
Air humidity:	5-85% (non-condensing)
Complaints:	See page 12
Producer:	Ropox A/S, DK-4700 Naestved, Tel.: +45 55 75 05 00 E-mail: info@ropox.dk - www.ropox.com

5. Schematic diagram of frame

All connections to the table must be flexible to ensure that the table moves freely within the range of adjustment.

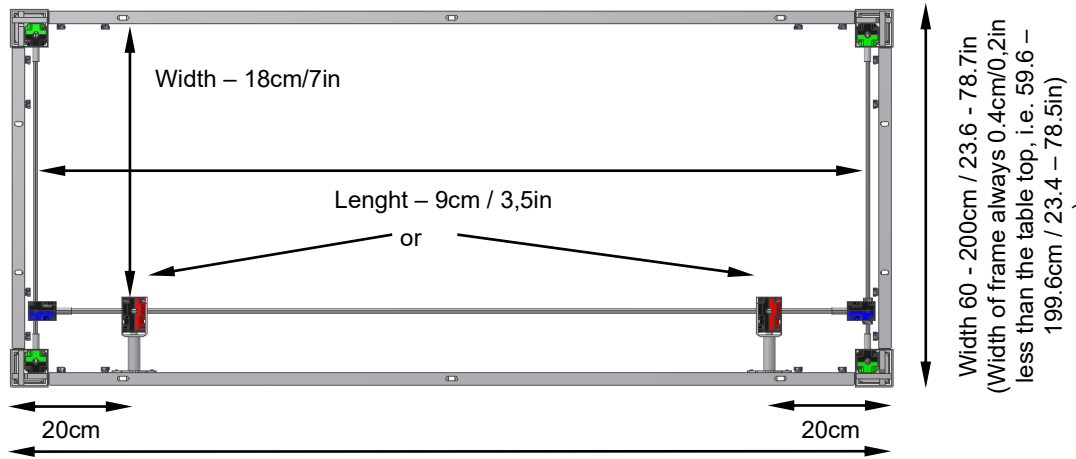

For table top length 60 - 300cm / 23.6 - 118.1in
(Length of frame always 0.4cm/0.2 less than the table top,
i.e. 59.6 – 299.6cm / 23.4 - 117.9in)

Height: 58-88cm (H1)
22,8-34,6in

Height: 65-95cm (H2)
25,6 – 37,4in

Height w/wheels:
+ 6.5cm / 2,5in

Height: 78-108cm (H3)
30,7 – 42,5 in

Height: 78-108cm /
30,7 – 42,5 in
w/wheels (H4)

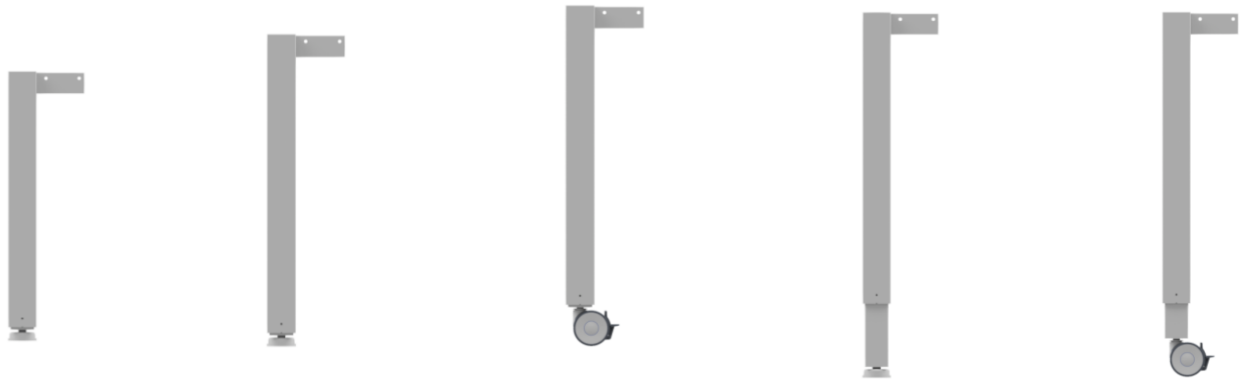

Size of frame without middle support:
Length 60-300cm / 23,6 – 118,1in
Width 60-120cm / 23,6 – 47,2in

Size of frame with middle support:
Length 60-300cm / 23,6 – 118,1in
Width 121-200cm / 47,6 – 78,7in

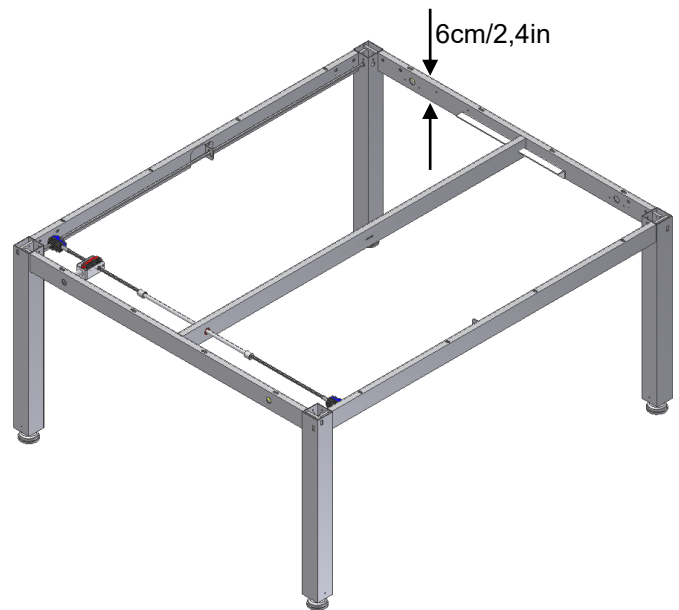
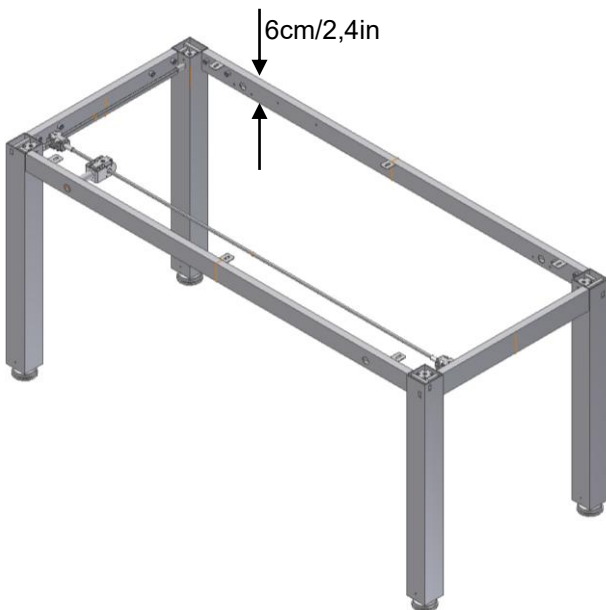

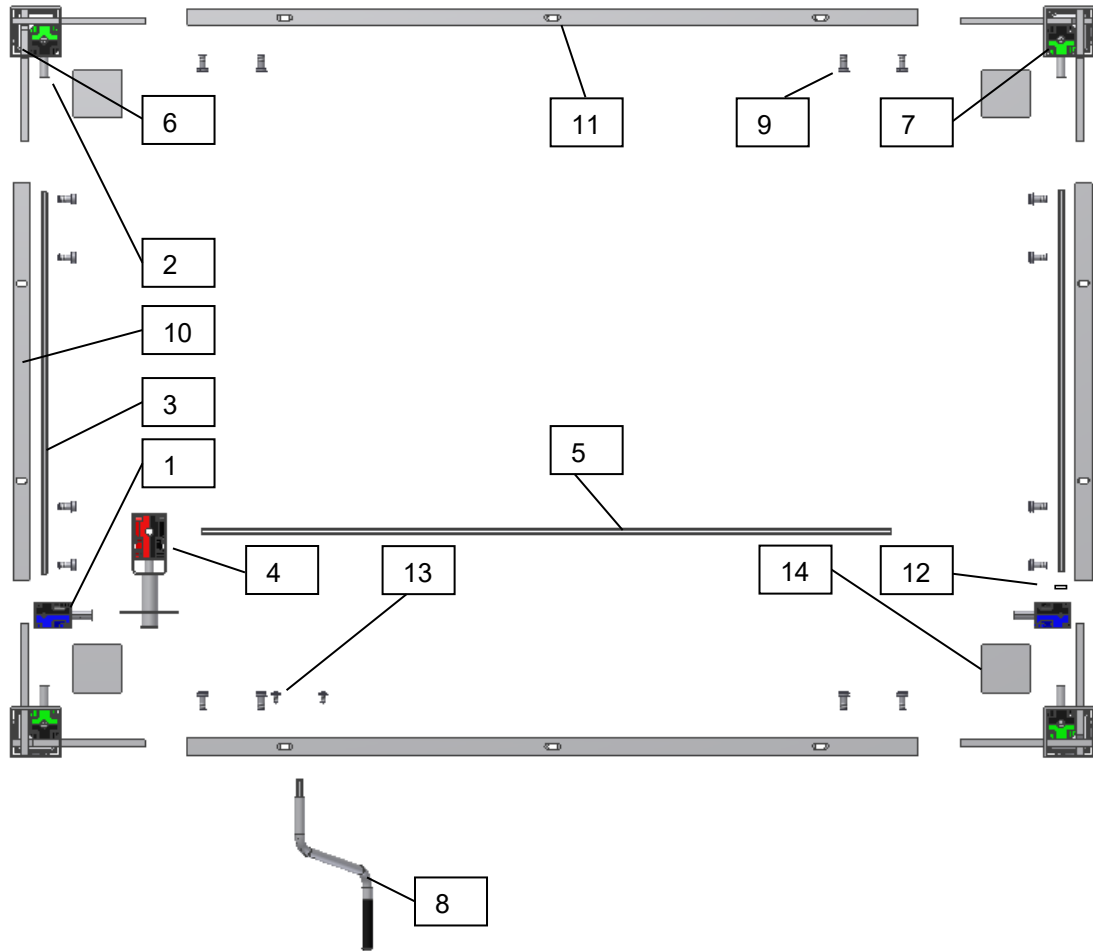

Component	Item No.	Pcs.
1. Gearbox	96000656	2
2. Shaft adapter, outside Hex7, inside Hex6	30*12999-047	4
3. Side fascia shaft, Hex6. Length = frame width – 13.8cm/5,4in		2
4. Gearbox for crank handle, Fixture & Bushing	30*12999-148	1
5. Front fascia shaft, Hex7. Length = frame length – 16.7cm/6,5in		1
6. Leg 1		2
7. Leg 2		2
8. Handle	20*60320-297	1
9. Allen screw M8x16	95010003	16
10. Side fascia profile, Length = frame width – 12.4cm/4,9in		2
11. Front fascia profile, Length = frame length – 12.4cm/4,9in		2
12. Stop ring incl. screw	98000-555	2
13. Screw ø4.8x13, Torx	95091012	2
14. Cover plate	50*40000-025	4

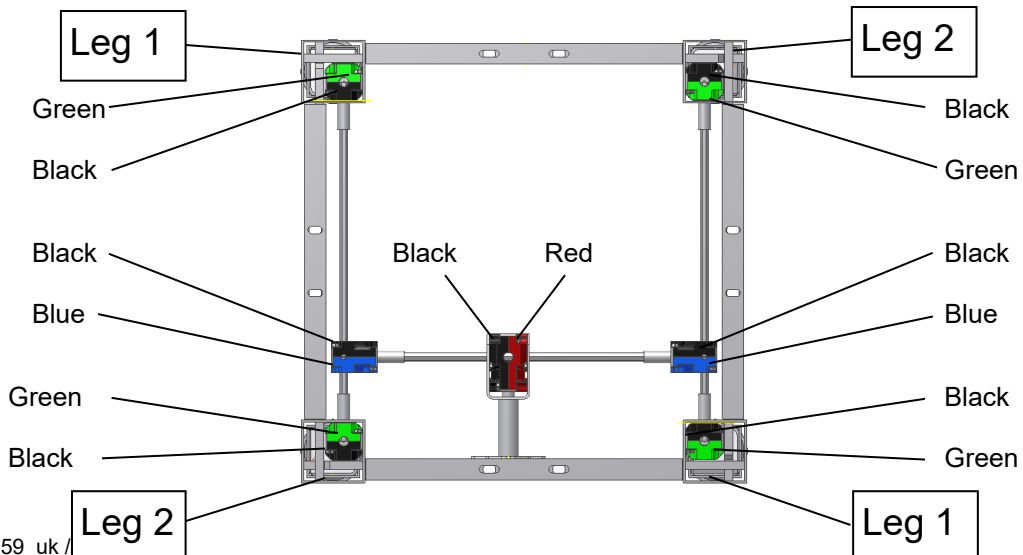

6. Mounting instructions, illustrations



Mounting must always be carried out by competent personnel.

Prior to mounting, check that all parts have been provided. See list of components, section 7.

6.1 Assembly of frame

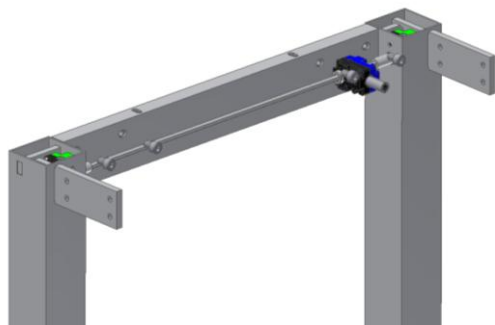
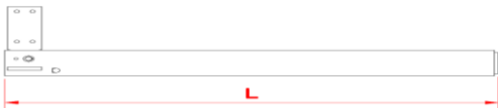

6.1.1 Check that the height (L) of all four legs is identical. May be adjusted on the hexagonal shaft. Place side fascias on a plane surface and mount legs. See label on legs.

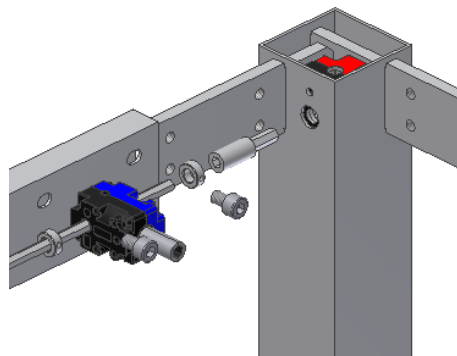

6.1.2 At the opposite end of the handle fit a stop ring on either side of the angular gear. Do not tighten the stop rings till the frame has been assembled.

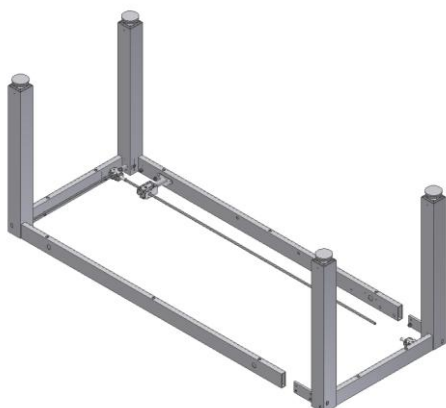

6.1.3 Now mount the two front fascias. Tighten the bolts securely.

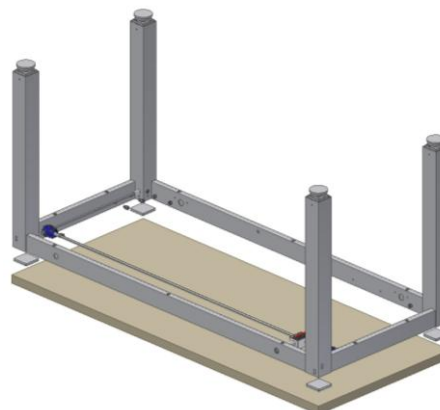

6.1.4 Place the frame on the table top and push the cover plates between legs and table top. Centre the frame in relation to the table top.

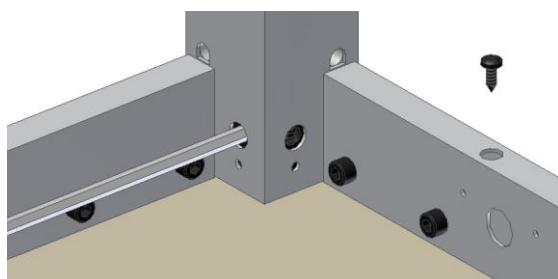

6.1.5 Fix the table top with screws through the holes of the fascias.

6.2 Mounting of wheels (option)



6.2.1 Mount the wheels. Do not forget to fit three washers on each wheel.

7. List of components

Set of legs H1, 50-41110:

1 set



Set of legs H2, 50-41210:

1 set

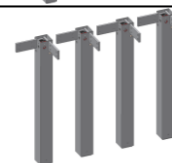

Set of legs H3, 50-41870:

1 set



Set of legs H4, 50-41875:

1 set



Front fascias for L=xxx cm, 50-42xxx:

Shaft Hex7 (fascia length – approx. 5cm/2in)

1 sets
1 pc.

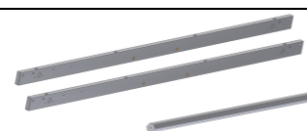

Side fascias for W=xxx cm, 50-44xxx:

Shaft Hex6 (fascia width + ca.2.5cm/1in)

1 set
1 pc.

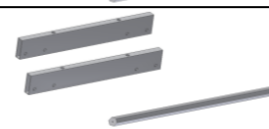

Handle for 4Single 50-47010-9:

1 pc.



Gearbox 96000656:

2 pcs.



Shaft adapter 30*12999-047:

4 pcs.

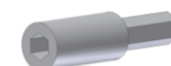

Gearbox for handle 30*12999-148:

1 pc.

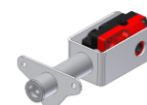

The Gearbox contains:

Gearbox 96000688

Fixture for shaft extension 30*12999-051

Bushing 30*12999-052

1 pc.
1 pc.
1 pc.



Allen screw M8x16 95010003:

16 pcs.



Screw ø4.8x13 95091012:

2 pcs.



Stop ring incl. screw 30*65500-084:

2 pcs.



8. Options

Brake wheels, black (4 wheels) 50-41600:

Increase the table height by 6.5 cm2,5in
incl. 12 washers (95170510)

1 set



9. Safety in use

- 4Single must only be used by persons, who have read and understood these instructions.
- 4Single is an activity table and should not be used as a lifting table or person lifter,
- Always use the table in a manner excluding the risk of damage to persons or property. The person operating the table is responsible for avoiding damage or injury.
- Children or persons with reduced observation capability should only operate the table when supervised.
- If the table is used in publicly accessible locations where children or persons with reduced observation capability may get near the table, the person operating the table must pay attention to those present in order to prevent dangerous situations.
- Make sure that there is free space above and below the table to allow height adjustment.
- Do not operate the table in case of defects or damage.
- Do not overload the table and make sure that the load distribution is correct.
- Do not use the table in an explosive environment.
- In connection with inspections, service or repairs always remove weight from the table.
- Modifications, which may influence the operation or construction of the table, are not allowed.
- Installation, service and repairs must be carried out by competent personnel.
- If the table has not been assembled according to these mounting instructions the right to complain may become void.
- Only use Ropox original spare parts as replacement parts. If other spare parts are used, the right to complain may become void.

10. Cleaning/ maintenance

10.1 Cleaning of frame

Clean the frame with a wrung cloth with lukewarm water and a mild detergent. Do not use enchansts or abrasives or grinding cloths, brushes or sponges.

Dry the frame after cleaning.

10.2 Maintenance



Inspections, service and repairs must be carried out by competent personnel.

The frame is maintenance-free and the moving parts have been lubricated for life. For reasons of safety and reliability we recommend inspection of the frame once a year:

- Check that all bolts have been securely tightened.
- Check that the table moves freely from bottom to top position.

After each inspection, fill in the service schedule.

Only use Ropox original spare parts for replacement of parts. If other spare parts are used, the right to complain may become void.

10.3 Service schedule, operation and maintenance

Service and maintenance Serial No.
Date: _____
Signature: _____
Remarks: _____

Service and maintenance Serial No.
Date: _____
Signature: _____
Remarks: _____

Service and maintenance Serial No.
Date: _____
Signature: _____
Remarks: _____

Service and maintenance Serial No.
Date: _____
Signature: _____
Remarks: _____

Service and maintenance Serial No.
Date: _____
Signature: _____
Remarks: _____

Service and maintenance Serial No.
Date: _____
Signature: _____
Remarks: _____

Service and maintenance Serial No.
Date: _____
Signature: _____
Remarks: _____

Service and maintenance Serial No.
Date: _____
Signature: _____
Remarks: _____

11. Complaints

See General Terms of Sale and Delivery on www.ropox.com

ROPOX A/S

Ringstedgade 221
DK – 4700 Naestved
Tel.: +45 55 75 05 00
E-mail: info@ropox.dk
www.ropox.com