

# FlexiElectric Corner

Mounting Instructions, Supplement to FlexiElectric User Manual

## 1. Introduction

Planning, installation and normal use must only be carried out if the FlexiElectric Manual is used in combination with these Mounting Instructions.

All other information, including use and technical data will be found in the FlexiElectric Manual.

**Producer:** | Ropox A/S, DK-4700 Næstved, Tel.: +45 55 75 05 00  
E-mail: [info@ropox.dk](mailto:info@ropox.dk), [www.ropox.dk](http://www.ropox.dk)

- Slide the first leg onto one of the aluminium profiles and pass the hexagonal shaft through the hole of the leg. Tighten the screws lightly.

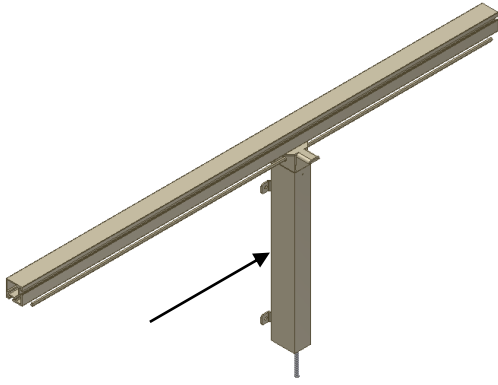

- Slide the bracket into the aluminium profile. **MUST** be placed over the leg. Tighten the screws lightly.

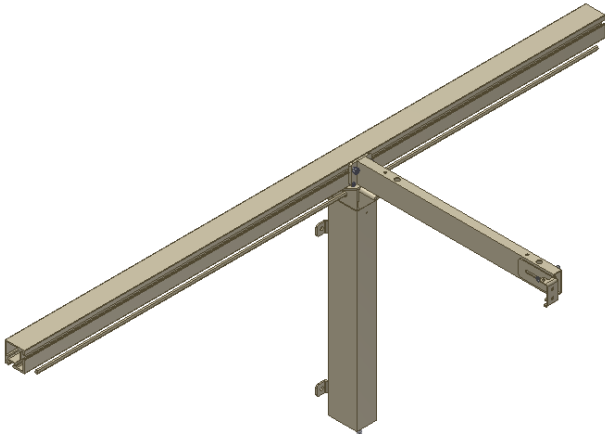

- Slide the nut of the motor fixture into the aluminium profile on the underside and guide the hexagonal shaft through the motor. Tighten the screws lightly.

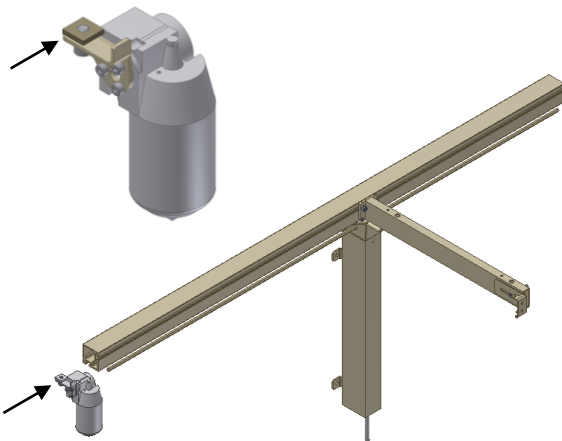

- Place the motor beside the leg and tighten the screw lightly.

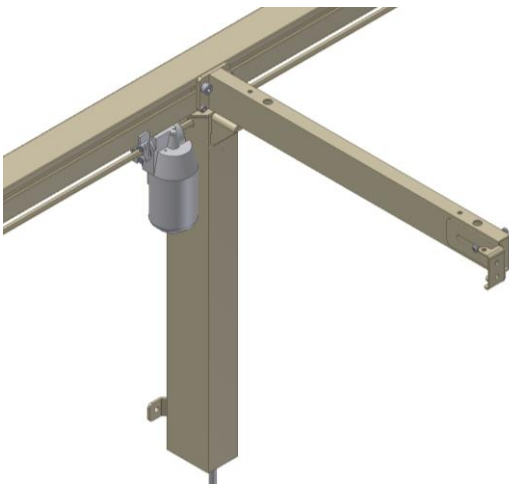

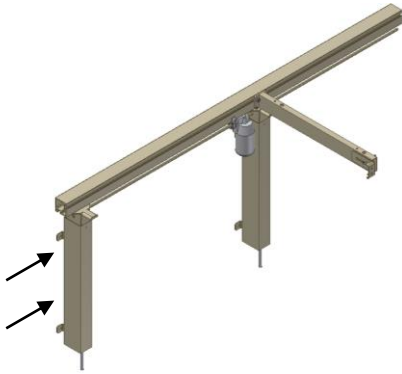

- Slide the next leg into the aluminium profile. Tighten the screws lightly.



- Place the next bracket over the second leg. If extra brackets are required between the two brackets shown here, they must be mounted first. Tighten the screws lightly.

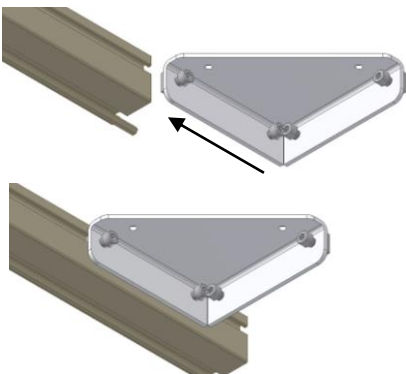

- Slide the two nuts of the angular fitting into the aluminium profile.!! Tighten the screws lightly.!!

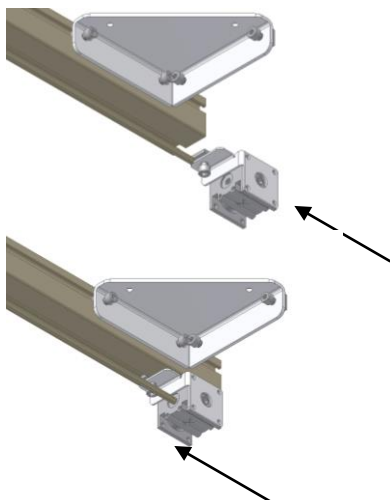

- Slide the nut of the angular gear casing into the aluminium profile. Important!! See that the gear is placed as illustrated!! Place the hexagonal shaft in the gear casing. Tighten the screws lightly.

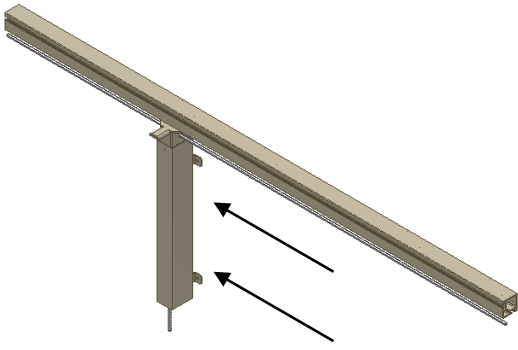

- Now assemble the other side following the same procedure. Don't tighten the screws till the whole frame has been assembled.  
Place the leg.

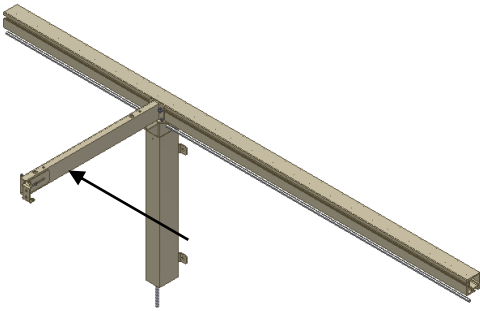

- Place the bracket.

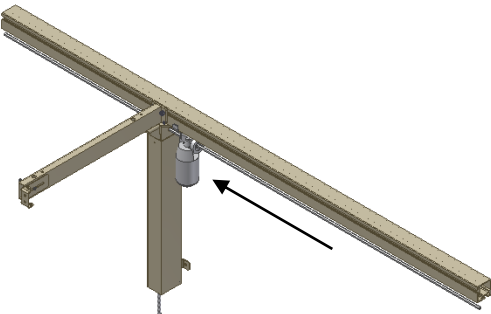

- Place the motor.

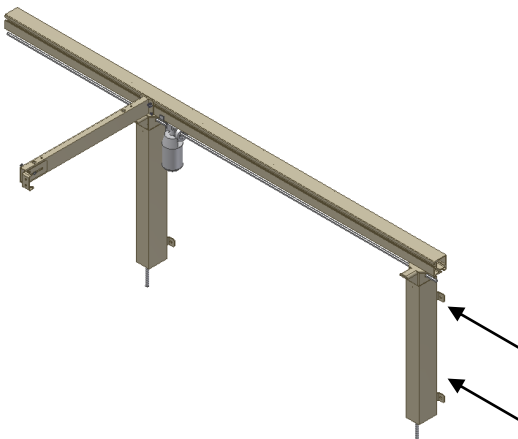

- Place the leg.

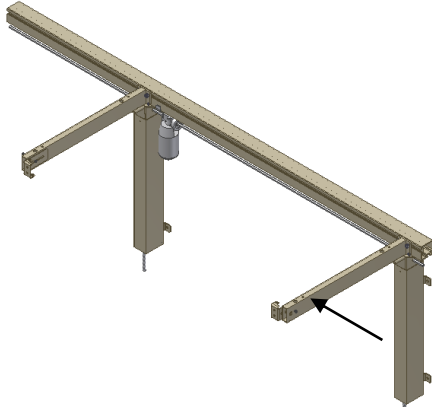

- Place the outermost bracket.

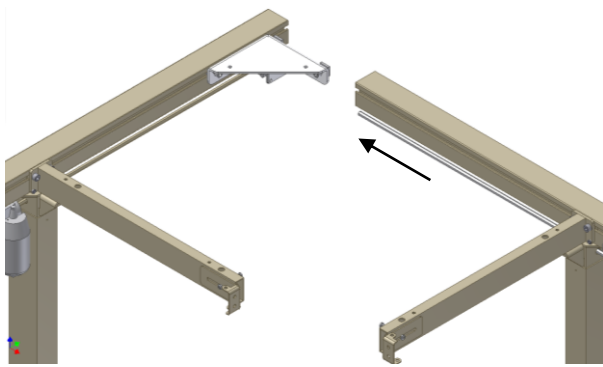

- Now assemble the two frames in the angular fitting. See that both hexagonal shafts have been pressed home in the gear casing.

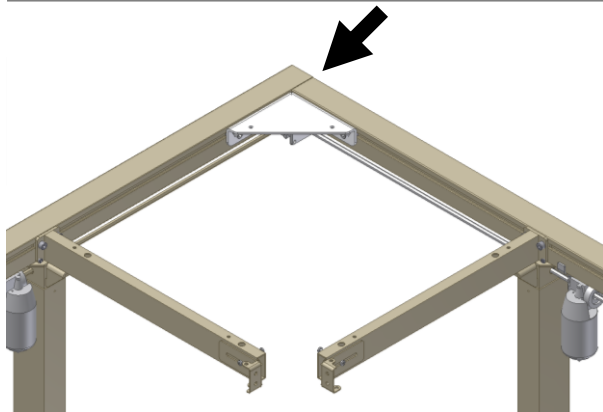

- Place the aluminium profiles so that they are flush in the corner.

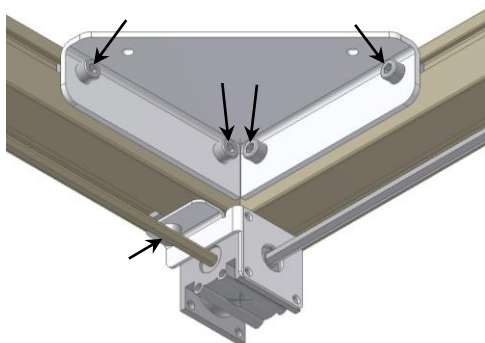

- Tighten the four screws of the angular fitting and one screw of the gear casing fitting.

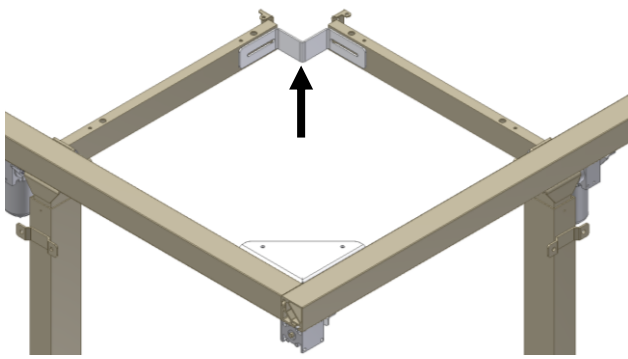

-  
- Mount the assembly fitting on the two brackets in the corner of the frame. Move the legs from side to side until the brackets fit as illustrated. Tighten the two screws.

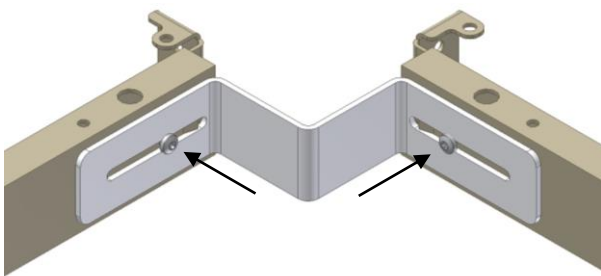

- Tighten the two screws.



- When all legs and brackets have been aligned and placed in the required position, tighten all screws!

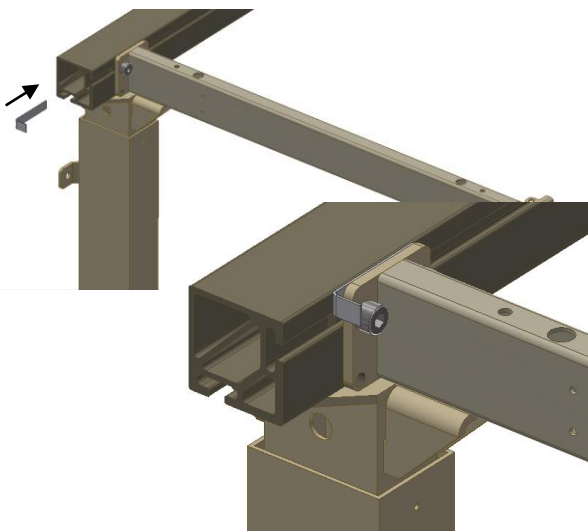

- If support arm isn't level but points upwards, this can be rectified by mounting included angle between support arm and aluminum profile!

Before use follow the instructions of the FlexiElectric User Manual!



**ROPOX A/S**

Ringstedgade 221  
DK – 4700 Næstved  
Tel.: +45 55 75 05 00  
E-mail: [info@ropox.dk](mailto:info@ropox.dk)  
[www.ropox.dk](http://www.ropox.dk)