



All-in-One Hoist 200kg

User manual



This manual should always be in close proximity of the product

Table of content

1. Symbols used in this manual	4
2. General safety	4
2.1 Product Unit label	6
3. General requirements	7
3.1 Product information.....	7
3.2 Product description	7
3.3 Intended use	8
3.4 Intended operator	8
3.5 Contraindications	8
3.6 Essential performance	8
3.7 Basic safety.....	8
3.8 Nonclinical functions	8
3.9 Product dimensions	8
4. Instructions for use	10
4.1 Assembly instructions	10
4.2 Mounting and dismounting of arm with spreader bar and stand-up hoist module.....	11
4.3 Operating the product	12
4.3.1 Operating instructions.....	12
4.3.2 Emergency situation	12
4.3.3 Stability function	13
4.4 Recharging the battery	14
4.5 Safety function, liftingmotor	14
4.6 Safety function, control unit	14
4.7 Emergency lowering	15
4.8 Brakes.....	15
4.9 Size guide for Domino slings	16
4.9.1 Size information	16
4.9.2 Dimensions for slings	16
4.10 Transfer – person lifting	17
4.10.1 Lifting from wheelchair.....	17
4.10.2 Placing in wheelchair.....	17
4.10.3 Lifting to and from bed.....	18
4.10.4 Lifting from floor	18
4.11 Transfer – Stand-up hoist	18
4.11.1 Lifting from chair	19
4.12 Installation of accessories.....	19
4.13 Electrical component diagram	20
5. Troubleshooting	20
6. Cleaning	21
7. Maintenance	21
7.1 Periodic maintenance	21
7.2 Daily check.....	21
7.3 Monthly maintenance.....	22

7.4	Yearly inspection	22
7.5	Maintenance report mechanical parts	23
7.6	Maintenance report actuator/lifting motor	24
7.7	Lifetime of actuator/lifting motor.....	25
7.7.1	Table to determine an actuators lifetime.....	25
8.	Component part list.....	26
8.1	Spare parts	26
9.	Environmental protection	27
10.	Electromagnetic compatibility	27
10.1	Suitable Environments.....	27
10.2	Cables.....	27
10.3	RF portable equipment	27
11.	Complaints	28

1. Symbols used in this manual

Warning symbol Indication of potentially hazardous situation. If not avoided, it can result in serious injury or death.	
Caution Symbol Indication of potentially hazardous situation which may result in minor or moderate injury. It may also be used to alert against unsafe practices.	
Notification Symbol This symbol is used to notify correct use and handling of the product.	

2. General safety

	<p>This manual must be read and understood before use. Always keep this manual in close proximity of the product.</p> <p>The use, installation and service of this product must be in compliance with this manual to avoid accidents and serious personal injury.</p> <p>Never use or handle this product in other ways specified in this manual as it can result in personal safety hazards and/or cause damage to the product.</p> <p>Persons installing and/or using this product either as operator or user should have the necessary safety information and access to this manual.</p> <p>If the supply cord is damaged, it must be replaced by the manufacturer, its service agent or similarly qualified designated persons in order to avoid a hazard.</p>
--	--



Do not perform repairs, disassembly or assembly operations, add-ons, re-adjustments or modification of the product beyond what is described in this manual. These must be carried out by Ropox or Ropox authorized personnel. Do not perform service while in use.

This appliance can be used by children aged from 8 years and above and persons with reduced physical, sensory or mental capabilities or lack of experience and knowledge if they have been given supervision or instruction concerning use of the appliance in a safe way and understand the hazards involved. Children shall not play with the appliance. Cleaning and user maintenance shall not be made by children without supervision.

Do not use the product if it has defects or have become damaged before being repaired or replaced.
If the control box makes unusual noise or smells, switch off the mains voltage immediately.

Take care that the cables are not damaged.

Unplug the mains cable on mobile equipment before it is moved.

The products must only be used in an environment that corresponds to their IP protection.



The information in this manual is based on correct installation in accordance with installation instructions for this product.

Ropox cannot be held liable if the product is used in any way that differs from stated in this manual and/or installation instruction.

Ropox reserve the right to amend this manual and reference documents without prior notice.

2.1 Product Unit label

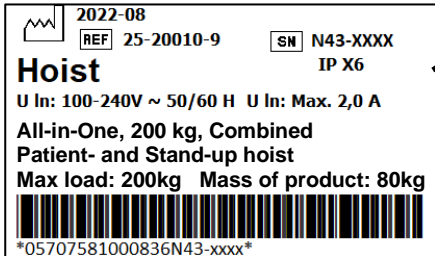

	This product is CE-marked in accordance with: European Medical Device Regulation (EU)2017/745 Council Directive 2011/65/EU, RoHS
	Manufacturer name and address
	Date of production
REF	Stock number
SN	Serial number
	Operating interval of electrically operated equipment. The use of electrical height adjustable equipment can run at maximum 2 minutes, followed by an 18-minute break.
	Type B applied part. The product complies with IEC 60601-1 requirements to provide protection against electric shock.
	Consult manual for important safety related information, warnings and safety precautions.
	Class II, double isolated electrical components.
	Do not dispose as unsorted municipal waste. Product must be returned to a designated recycling station.
	Mobile phones or other portable RF emitting equipment should be no closer to the product than 30cm.
	Operating and storing temperatures may not exceed 5-40C°
	Consult manual before use

3. General requirements

3.1 Product information

Manufacturer:	Ropox A/S Ringstedgade 221, DK-4700 Naestved +45 55 75 05 00 Email: Info@ropox.com			
Product models	Part number	Model	Configuration	UDI
	25-20520-8	Combined	Patient/stand-up lift	57075810805SD
	25-20521-8	Patient hoist	Convertible	57075810807SH
	25-20523-8	Stand-up hoist	Convertible	57075810809SM
	25-20524-8	Patient hoist	Not convertible	57075810806SF
25-20525-8	Stand-up hoist	Not convertible	57075810808SK	
MDR Class 2017/745	Class I			
MDD Class 93/68/EEC				
Applied part classification 60601-1	Type B applied part			
MEE Class 60601-1	Class II			
Intended environments according to IEC 60601-1-2	This product is to be used only in: Professional Healthcare Environment Homecare Environment <i>The device is not intended for use in special environments as defined by IEC 60601-1-2</i>			
Maximum user weight according to DS/EN ISO 10535:2007	200kg			
Power supply	100-240V ~50/60Hz			
I in	Max 2.5A			
Intermittence	10% - 2min use / 18min pause			
Height adjustment	55-180 cm			
Speed of actuation	≈ 15mm/s			
Number of lifts per charge (up and down)	Approx. 75			
IP rating	IPX4			
Ambient temperature range	-5 °C to +40 °C Transport and storage +5 °C to +40 °C Operation			
Relative humidity	20% to 80% - non-condensing			
Materials in contact with patient	Sling (variants)	Polyester		
	Spreader bar	St37 tube construction with powder coating		

Accessories	
<i>Item number</i>	<i>Model/specification</i>
25-20517-9	Stand-up kit 200 kg
25-20516-9	Patient hoist kit 200 kg
25-29950-9	Wall charging depot incl. battery
25-29030-9	Battery

3.2 Product description

All in one hoist system is a mobile hoist for people with limited mobility who need help with relocation. The health personnel can, using different slings, lift people up to 200 kg respectively.

3.3 Intended use

The product is used in situations where a patient has to be lifted from one stationary bed to another stationary bed. The product must not be used for patient transport. The product must always be used with Ropox suitable lifting slings.

3.4 Intended operator

Intended operator must have relevant health professional training before using the product, as well as have read and understood this guide. Children, patient, or lay person is not considered a suitable operator.

3.5 Contraindications

If the patient does not have the upper body strength to sit in the sling (with or without holding onto the handles), they have a higher risk of slipping out of the sling. This could lead to a fall.

3.6 Essential performance

The lifting motor has a mechanical emergency lowering facility. In case of failure of electronics during use, this can be used to lower the patient to a safe height.

3.7 Basic safety

The battery must always be checked for capacity before starting work. An audible warning will sound if the battery capacity is too low. The product is equipped with an emergency stop, its function must also be checked before use.

3.8 Nonclinical functions

The product has no clinical effect. This is a patient lifter.

3.9 Product dimensions

	25-20010	25-20020
	25-20020	25-20030
	25-20040	25-20050
	Patient hoist	Stand-up hoist
Lifting capacity	200 kg	200 kg
Min. lifting height, lifting hook	58 cm	95 cm
Max. lifting height, lifting hook	177 cm	191 cm
Lifting travel	119 cm	96 cm
Length chassis frame	122 cm	122 cm
Length legs	98 cm	98 cm
Min. inside distance between legs	54 cm	54 cm
Max. inside distance between legs	118 cm	118 cm
Min. outside distance between legs	69 cm	69 cm
Max. outside distance between legs	133 cm	133 cm
Height of chassis frame	12 cm	12 cm
Free height under legs	7 cm	7 cm
Wheel diameter	100/75 mm	100/75 mm
Turning circle	131 cm	131 cm
Weight of arm with spreader bar	6,5 kg	
Weight of fork-shaped bar		5,5 kg
Weight of knee support with base plate		8,5 kg
Weight of battery	3,0 kg	3,0 kg
Total weight	51,0 kg	58,5 kg
Approximate number of lifting operations per charging	75	75

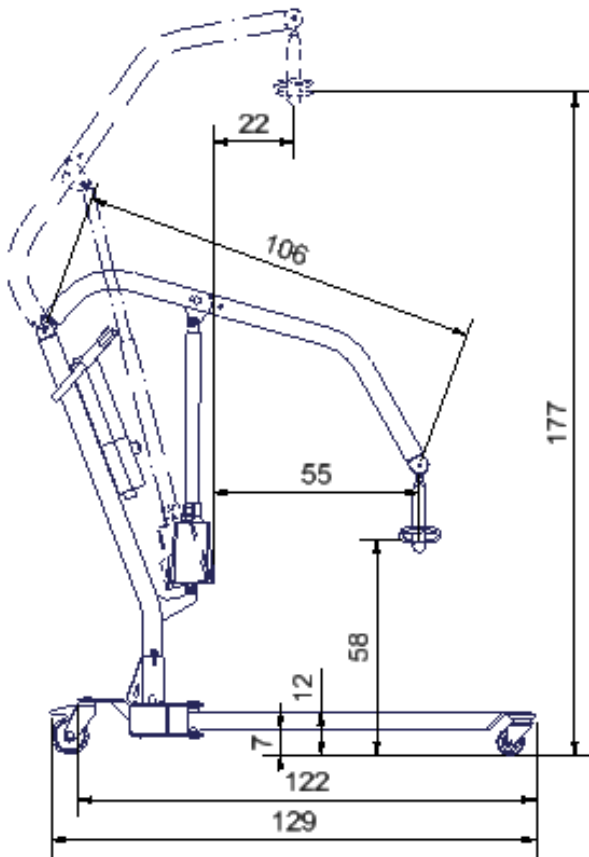

Patient hoist

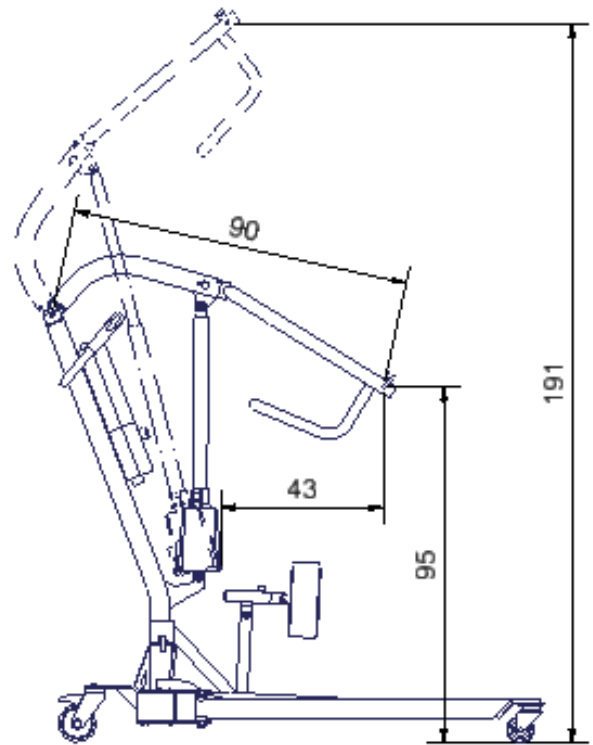

Stand-up hoist

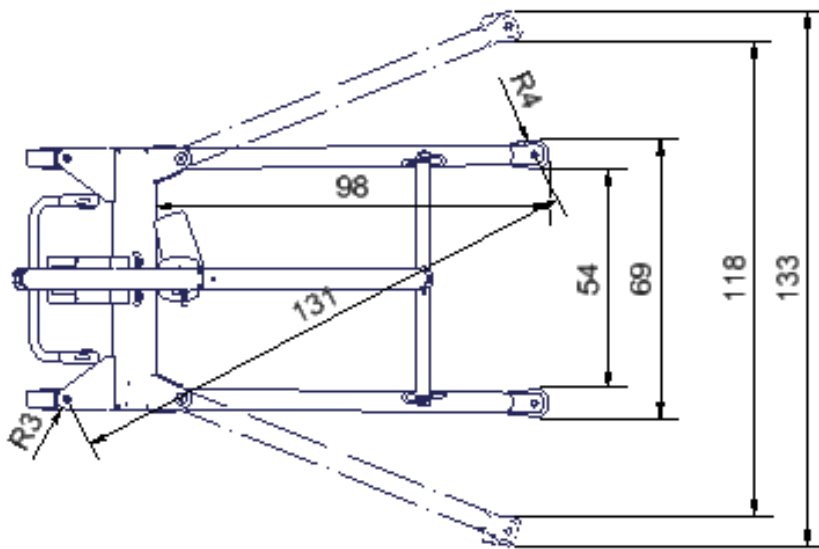

	<p>Note! Dimensions in centimeters.</p>
---	--

4. Instructions for use

4.1 Assembly instructions

1. Place the lifting mast in the mast holder of the frame. Tighten the two screws with the 5mm Insex wrench provided and use locking nut on opposite site.
2. Connect the cable from the leg spreading motor to the control unit in output terminal 2, see section 4.13 "Electrical component diagram".

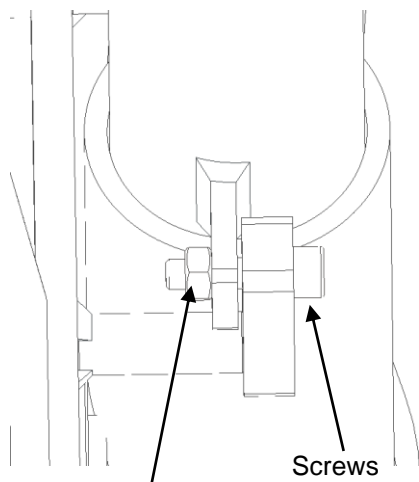

M6
Locking nut

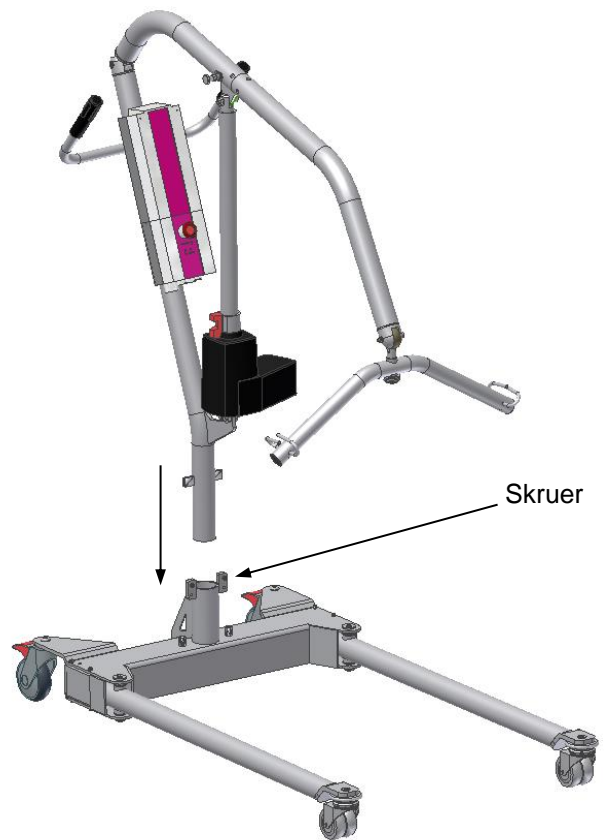

4.2 Mounting and dismounting of arm with spreader bar and stand-up hoist module

Mounting

1. Brake the rear wheels.
2. Hold the lifting module (turn it through 90°) so that the locking pin may be pushed into the corresponding slide rail of the lifting mast.
3. Be aware that the bar may swing. We recommend holding on to it.
4. Push in the lifting module.
5. Then turn it 90° clockwise until you hear a click.
6. Make sure that the arm has been properly locked.
7. If the hoist is going to be used as a stand-up hoist, hook on the knee support with base plate.
8. Now the hoist is ready for use.



Dismounting

1. Brake the rear wheels.
2. If the hoist has been used as a stand-up hoist, lift off the knee support.
3. Pull the locking pin while turning the lifting module 90° counter-clockwise.
4. Be aware that the bar may swing. We recommend holding on to it.
5. Now the lifting module may be pulled out.



Note!

The lifting module is heavy. Proper lifting technique is advised.



4.3 Operating the product

	<p>Note!</p> <p>It is important that you are familiar with the use of the hoist and its functions, and that it works properly. For the best possible safety, all users of the patient hoist must read this user manual before using the patient hoist.</p>
--	---

For the All-in-One you can use any of Ropox Domino slings.

4.3.1 Operating instructions

- Check that the emergency stop has been released. If not, turn the button clockwise until release.
- The hoist is operated by means of the hand control unit. The two upper buttons control the lifting/lowering movement, whereas the two lower buttons control the leg spreading facility. It is not possible to use two functions simultaneously.
- Check that the sling provided is correct for the lifting operation to be performed. This applies to size as well as shape. Further information about the choice of slings will be found in "Domino Slings User manual".
- The battery should be recharged regularly, to ensure that the hoist is always available (e.g. every night).

	<p>Note!</p> <p>In case of erroneous operation of the hand control unit (e.g. too quick change of direction) the hoist does not react. Let go of the push button – wait a few seconds and press again.</p>
--	---

4.3.2 Emergency situation

Emergency stop and emergency lowering (electrical and mechanical) should be used in emergencies only. Should it be necessary to activate the emergency functions, contact the distributor before using the hoist again.

4.3.3 Stability function

The lift has a leg spreading function, which is designed to increase the stability of the lift during lifting of a patient. While parallel, the legs have a minimum inside distance between each other of 54cm, but can be increased to 118cm. This allows the lift to get as close as possible to a person in a wheelchair.

It is **IMPORTANT** that during lifting of a patient, that the legs are spread out as much as possible, as you might otherwise risk the lift having reduced stability.

This is not applicable to transporting a patient in the lift, in which case you'd like the legs to be parallel, to be able to get in through doors and be free of obstacles.



The leg spreading function is controlled with the same remote as the lifting arm.



	<p>Warning!</p> <p>The legs must be spread out during lifting of a patient to or from a seated or lying position!</p>
---	--

4.4 Recharging the battery

- The battery **must** be recharged after approx. 35 lifting operations – i.e. at 50% battery capacity. In case of continued use you will hear an acoustic signal. The battery can still be used, but it will affect its recharging capability.
- We recommend charging as soon as the hoist is not being used for a longer period of time, e.g. every night. The battery cannot be over-charged and it is only "healthy" for the battery to be recharged often as it increases the battery life.
- Charging is made directly in the control unit by means of the mains cable provided. Insert the cable into the wall outlet and the control unit, see section 4.13, and switch on power. The hoist cannot be used when connected to mains voltage.
- A green light on the control unit indicates connection to mains voltage. A yellow light indicates that the battery is being recharged.
- When the battery has been fully charged, the yellow light will be out.
- Full recharging takes 4-5 hours.
- If charging is made via a wall-mounted charging station (optional) a battery may be constantly charged in the station. The batteries may be easily switched by means of the snap system on top of the battery box.



Note!

Make sure that the plug from the battery is correctly inserted in the control box, if the plug has been pulled out, before using the lift again.



4.5 Safety function, liftingmotor

The lifting motor is provided with a safety function, spline, against jamming. If the lifting arm meets with resistance during lowering, the movement of the arm will stop automatically. Thus, a person cannot get jammed between the lifting arm and the bed.

4.6 Safety function, control unit

- Protective motor switch for lifting and leg spreading, protecting against overloading
- Short-circuit protection
- Acoustic signal sounding when the batteries need charging (at 25% charge)
- Electrical emergency lowering if the hand control unit does not work
- Built-in charger



Warning!

Owing to the safety function on the motor the lifting arm and spreader bar may fall freely to the spindle of the motor. Therefore, make sure that the lifting arm does not "hang", that is has always been pressed down to ensure that it rests on the spindle of the motor before and after all lifting operations. This is important as otherwise an injury may result if the lifting arm "falls" down.

Emergency stop

If the hoist is to be stopped owing to an emergency – press the red button on the control unit. When the button has been depressed the electrical functions of the hoist cannot be activated and the battery indicator has been switched off.

4.7 Emergency lowering

If the hoist is to be lowered and the hand control unit does not work, there are two possible solutions:

- The electrical emergency lowering of the control unit (marked emergency), see section 4.13. Press with a ball pencil or the like and the person will be lowered slowly.
- The mechanical emergency lowering of the lifting motor. Pull up the red handle, see drawing.

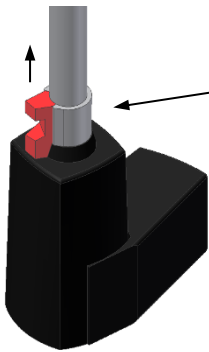

The lifting motor has a mechanical emergency lowering facility. To release it, pull the red handle.

4.8 Brakes

The hoist may be braked on the two large rear wheels. Press down the rear part of the brake with the foot to brake the hoist. Release the brake by pressing the front part of the brake with the foot.

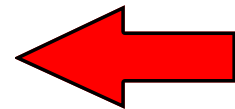
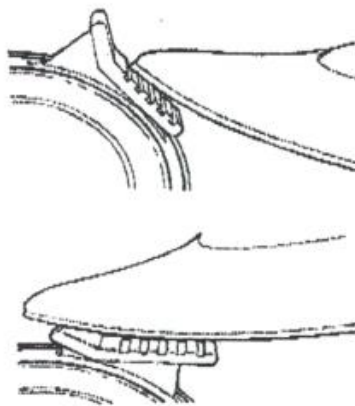

Brake

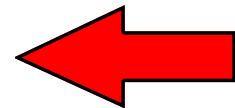

Release







Note!

Never brake the hoist during lifting except when used in stand-up mode.

4.9 Size guide for Domino slings

In choosing the correct sling to use, the “Facts-Label” on the sling can be used. Alternatively, the following instructions can be used. This section can also be used to determine which slings to choose, when acquiring the product. It's recommended to use the Domino slings exclusively with the Ropox All-in-One hoist.

4.9.1 Size information

Type	Classic / Thorax (w/ padding)	All	All	Thorax (w/ padding)
Height	145 – 175cm	165 – 185cm	175 – 195cm	
Weight	40 – 60kg	60 – 80kg	80 – 100kg	>100kg
Size	 Small	 Medium	 Large	 X-Large

4.9.2 Dimensions for slings

Different slings come in up to four different sizes. For these, the waist size (W), or the back height (H), are provided in order to, together with height and weight, choose the best sling for the patient. The waist size is indicated as the **maximum size**. The dimensions are as follows:

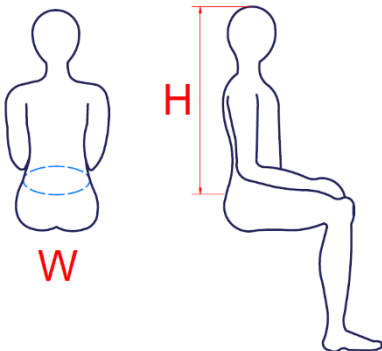

Type	Size	W	H
Active	Medium	See height and weight information	
	Large		
Hygiene	Medium	110 cm	
	Large	125 cm	
Classic	Small		75 cm
	Medium		85 cm
	Large		95 cm
Thorax (w/ padding)	Small	70 cm	
	Medium	100 cm	
	Large	130 cm	
	X-Large	150 cm	
Thorax (w/o padding)	Medium	100 cm	
	Large	130 cm	

4.10 Transfer – person lifting

- It is important that the user is familiar with the hoist and that it works satisfactorily before lifting a person.
- It is important to choose the correct type of sling for the lifting operation to be performed. This applies to size as well as shape. Further information about the slings will be found in "Instructions for the Use of Domino Slings".
- With a person in the hoist always move slowly in order to avoid swaying.
- Only use the hoist on surfaces with less than 5° gradient.
- Only brake the hoist when it is parked or standing on a sloping surface, e.g. in bathrooms.
- Never lift a person higher than necessary.
- Be aware of the maximum load of the hoist.

**Before lifting a client, try the hoist yourself.
Risk assessment shall be carried out to ensure that the
correct size, type and shape of slings is being used for
the patient**

4.10.1 Lifting from wheelchair

1. Mount the sling.
2. **Increase the width between the legs** of the hoist and move it to the chair.
3. Place the spreader bar above the person in the chair.
4. Lower the lifting arm and place the straps of the sling correctly in the hooks of the spreader bar. Make sure that all straps have been fitted correctly.
5. Lift the person a few centimeters above the seat of the chair - STOP – and make sure that the sling has been fitted correctly.
6. When the person is comfortable in the sling, lift him/her clear of the chair.
7. Pull the hoist away from the chair - STOP – adjust the legs of the hoist to parallel position before proceeding with the transfer.

4.10.2 Placing in wheelchair

To place a person in a wheelchair proceed in reverse order:

1. **Increase the width between the legs** of the hoist and move it to the chair.
2. Make sure that the person has been placed correctly in relation to the chair and lower the hoist slowly.
3. Check that the person is in the proper position during the entire operation.
4. When assisting a person in getting back into the chair, lower the person to just touch the chair.
5. If the chair can be tilted a little backward it is easier to place the person correctly. Also pull the straps on the back of the sling.
6. If two helpers are available, one may press gently on the knees of the person.



Note!

The wheelchair must be braked during transfer to and from the chair.
Be careful that sails do not jerk or pinch wires attached to the client

4.10.3 Lifting to and from bed

1. If the bed has an adjustable headrest and the client is capable of being raised a little, a raised headrest will facilitate application of the sling.
2. Place the lower edge of the sling so that it just covers the base of the spine.
3. If the client is to be transferred from wheelchair to bed, a raised headrest will also facilitate the operation. It will be easier to place the client correctly in the bed and to remove the sling straps.
4. As an alternative roll the client to a lateral position. Unfold the sling and place it so that the lower edge just covers the base of the spine.
5. Place the spreader bar above the bed and lower it to approx. 25 cm above the waist.
6. Fix the straps of the sling in the spreader bar.
7. Lift the client slowly approx. 2 cm above the bed and make sure that the sling is positioned correctly, and that the client is comfortable and properly supported.
8. Lift the client clear of the bed and transfer him/her to the required position.



Note!

Always adjust the sling before lifting the client completely clear of the bed .
The bed must be locked when moving to and from bed.
Be careful that sails do not jerk or pinch wires attached to the client

4.10.4 Lifting from floor

Make sure that the general condition of the client allows him/her to be lifted.

1. Follow the same procedures as when lifting from bed when placing the sling under the client.
2. Lift the client to a half-seated position and use a chair or a similar stable back support with a cushion.
3. Move the open end of the hoist towards the client and lift the legs of the client over one leg of the hoist.
Do not brake the hoist.
4. The hoist may be placed in the opposite position, i.e. with the head of the client towards the control unit of the hoist.
5. Lower the lifting arm and fix the straps of the sling in the spreader bar.
6. Lift the client slowly while checking that the sling is placed correctly and that the client is comfortable and properly supported.



Note!

When operating the hoist use the wheels opposite to the push handles as a pivot point. This will facilitate maneuvering.

4.11 Transfer – Stand-up hoist

- It is important that the user is familiar with the operation of the hoist and that it performs properly prior to lifting.
- It is important to choose the correct type of sling for the lifting operation to be performed. This applies to size as well as shape. Further information about the choice of slings will be found in "Instructions for the Use of Domino Slings".
- Transfer of a person in a stand-up hoist must only be made to and from seated position.
- The stand-up hoist must be braked during lifting.
- The client must not wear slippery clothes or underwear.
- Be aware of the maximum load of the hoist.

4.11.1 Lifting from chair

1. Apply the Thorax standing sling with the lower edge right above the waistband.
2. **Increase the width between the legs** of the hoist and move it to the chair.
3. Approach the client and place his/her legs on the base plate.
4. Push the hoist as closely to the client as possible – brake the hoist.

	<p>Warning!</p> <p>Make sure that the feet of the client do not get jammed between base plate and floor.</p>
---	---

5. Adjust the knee support so that it provides support right under the knees of the client.
6. Lower the lifting arm.
7. Place the lifting straps of the sling in the hooks of the fork-shaped lifting bar.
8. If the client can hold on to the lifting bar with his/her arms during lifting, use the middle step of the suspension strap.
9. If the client has but little stability and strength in the upper part of the body, use the outermost step of the suspension strap.
10. Tell the client to lean back in the sling and look up.
11. Now lifting may be commenced. If required, support the client during lifting.
12. Lift the client to standing position.
13. To prevent the sling from sliding upward, place the straps in a loop.

	<p>Note!</p> <p>We recommend lifting the client approx. $\frac{3}{4}$, so that the knees are slightly bent. Be aware of the pressure on the knees/lower part of the leg.</p>
---	--

4.12 Installation of accessories

Mounting of person and stand-up kit

1. Brake the rear wheels.
2. Hold the lifting module (turn it through 90°) so that the locking pin may be pushed into the corresponding slide rail of the lifting mast.
3. Be aware that the bar may swing. We recommend holding on to it.
4. Push in the lifting module.
5. Then turn it 90° clockwise until you hear a click.
6. Make sure that the arm has been properly locked.
7. If the hoist is going to be used as a stand-up hoist, hook on the knee support with base plate.
8. Now the hoist is ready for use.



4.13 Electrical component diagram

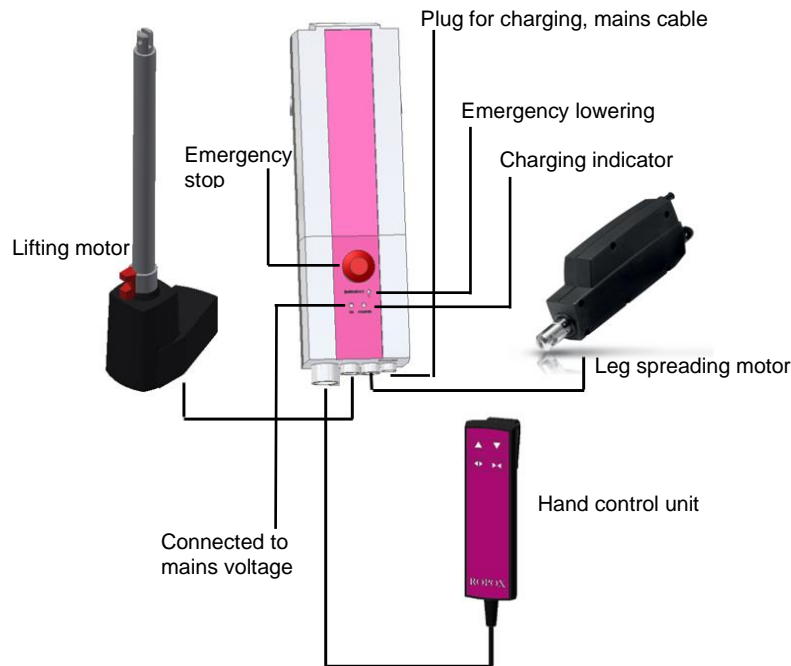

5. Troubleshooting

If the hoist does not work, check and test the following procedures before contacting an authorized distributor.

- Has the battery been charged?
- Has the emergency stop been released?
- Have all plugs been inserted correctly?
- Does the hand control unit work properly and has it been mounted correctly?
- Try with another hand control unit or charger.
- If the lifting arm cannot be lowered by means of the hand control unit, use mechanical or electrical emergency lowering, and the lifting arm will come down.

Symptom	Possible cause	Action
Indicator for mains voltage does not light up	- Mains voltage not connected - Control unit defective	- Connect mains voltage - Replace the control unit
The motors do not start. A click is heard from the relays of the control unit	- The plug has not been correctly inserted into the control unit - Motor defective - Control unit defective	- Insert the motor plug correctly into the control unit - Replace the motor - Replace the control unit
The motors do not start. No click is heard from the relays of the control unit	- Control unit defective - Hand control unit defective	- Replace the control unit - Replace the hand control unit
The control unit is completely dead. No click is heard from the relays of the control unit	- Battery completely discharged - Battery defective	- Charge the battery - Replace the battery
The control unit is in order except for one direction of one channel	- Hand control unit defective - Control unit defective	- Replace the hand control unit - Replace the control unit

6. Cleaning

Clean the hoist with a damp cloth wrung in warm water with a mild detergent. Electrical components may be dried with a firmly wrung cloth. Do not use water directly on these components. Never use solvents.

	Note! Do not use cleaning agents containing abrasive e.g. scouring powder, steel wool, scouring sponge. This product is not designed to be sterilized, autoclaving and sterilization beyond normal cleaning is may possibly change the product safety and function.
---	--

Preapproved cleaning agents

Trade name	Solution
Acticlör plus	1000ppm
S90 sanirens	1-3% peracid
FUTUR, Alkalisk rens	1% Solution [pH 9,5]
Overfladedesinfektion	70% Ethanol
Suverent Universalrengöring	1% Solution [pH 8]

7. Maintenance

	Note! Failing to comply with periodic maintenance may result of degrading of product function and safety.
---	---

7.1 Periodic maintenance

Always make sure that the mechanical and electrical systems of the hoist operate satisfactorily. In case of malfunction stop the hoist and check or repair it, as required. Malfunction may be a symptom of a defect, which may become worse and present a safety risk in critical situations. It is therefore important to check the hoist as described below.

7.2 Daily check

- Sling
1. Check that the slings are clean, If not, send them to the wash.
 2. Check for wear and that the seams are intact and not frayed. A worn sling must be replaced.
- Hoist
3. Check that the hand control unit works satisfactorily and is mounted correctly.
 4. Check that cables have been correctly inserted into the control unit.
 5. Check visually that shaft and bolted joints run smoothly and silently.
 6. Keep the hoist clean. A clean hoist is safer and has a longer life.

7.3 Monthly maintenance

Sling 1. Inspect the slings carefully and replace them in case of visible defects or wear.

Hoist 2. Check that hand control unit, control unit and battery have no visible defects.

3. Check that cables have been inserted correctly and are undamaged.

4. Check that the lifting motor is not bent and is undamaged.

5. Check that all shaft and bolts joints are undamaged and stable. Worn parts should be replaced.

6. Check that the wheels run smoothly. Clean them once a month.

7.4 Yearly inspection

Preventive service **must** be made once a year. Follow the procedures below.

- Forms to service report

Take a copy off the forms on page 23 and 24 and use them when filling out the service report. We recommend scaling them up to A4 size.

- Visual inspection

Inspect hoist frame and welds for wear, skews, or any other damage.

- Testing

Check all functions with and without load.

Check emergency stop.

Check battery and charger.

- Mechanical inspection, see also section 7.5

Inspect that all parts are moving freely and without any abnormal noise.

OBS! Bolt M6x50 holding Spreader bar should be dismantled and inspected visually.

OBS! Axle holding lifting arm should be dismantled and inspected visually.

Inspect, that bolts are tight.

- Electric inspection, see also section 7.6

Check actuator for damage, noise, and the fixtures.

Check the battery voltage with max load and a full lifting cycle. If below 19V the battery needs to be changed. Replace defective battery, if any.

Check wires for damage.

Check all plugs and sockets.

7.5 Maintenance report mechanical parts

Invoice address:		Delivery address:			
Repair	Mounting	Service		Warranty	
Lift type:		Serial No.			
Inspection carried out		OK	Defective	Repaired	Replaced
Lubrication of wheels					
Lubrication of load bearing shafts and hooks					
Welds					
Bolts / bushings					
Mast and arm connection					
Arm and lifting accessories					
Test of the leg-spreading function					
Switches and safety functions					
Test of batteries and recharging function					
Test of the seams of the Domino slings					
All bolts					
Lifting motor and leg-spreading motor. See separat pages regarding motors					
Other					
Functional test of the lift					
Consumption of spare parts					
Spare part No:		Products:			
Comments:					
Milage:		Time consumption:			
Date:		Performed by:			

7.6 Maintenance report actuator/lifting motor

Invoice address:		Delivery address:		
Repair	Mounting	Service	Warranty	
Lift type:		Serial No.		
Inspection carried out		OK	Not OK	Remarks
Powerconsumption without load				
Powerconsumption with max. load				
Noise				
Plastic				
Wires and cords				
Straightness and outbending when the actuator is completely out				
Looseness				
Fixing points				
Marks and dents				
Other				
Consumption of spare parts				
Spare part No:		Products:		
Comments:				
Milage:		Time consumption:		
Date:		Performed by:		

7.7 Lifetime of actuator/lifting motor

A service technician fills out the below points from the user information

How often is the lift used pr. day:

Actuators production date:

Expected changing of actuator:

7.7.1 Table to determine an actuators lifetime

Note!! The lifting actuator should be changed when it is max. 6 years or after 10.000 strokes.

Continue normal use

Consider changing

Actuator should be changed

Lifts pr. day	Age in years									
	1	2	3	4	5	6	7	8	9	10
1	365	730	1095	1460	1825	2190	2555	2920	3285	3650
2	730	1460	2190	2920	3650	4380	5110	5840	6570	7300
3	1095	2190	3285	4380	5475	6570	7665	8760	9855	10950
4	1460	2920	4380	5840	7300	8760	10220	11680	13140	14600
5	1825	3650	5475	7300	9125	10950	12775	14600	16425	18250
6	2190	4380	6570	8760	10950	13140	15330	17520	19710	21900
7	2555	5110	7665	10220	12775	15330	17885	20440	22995	25550
8	2920	5840	8760	11680	14600	17520	20440	23360	26280	29200
9	3285	6570	9855	13140	16425	19710	22995	26280	29565	32850
10	3650	7300	10950	14600	18250	21900	25550	29200	32850	36500
11	4015	8030	12045	16060	20075	24090	28105	32120	36135	40150
12	4380	8760	13140	17520	21900	26280	30660	35040	39420	43800
13	4745	9490	14235	18980	23725	28470	33215	37960	42705	47450
14	5110	10220	15330	20440	25550	30660	35770	40880	45990	51100
15	5475	10950	16425	21900	27375	32850	38325	43800	49275	54750
16	5840	11680	17520	23360	29200	35040	40880	46720	52560	58400
17	6205	12410	18615	24820	31025	37230	43435	49640	55845	62050
18	6570	13140	19710	26280	32850	39420	45990	52560	59130	65700
19	6935	13870	20805	27740	34675	41610	48545	55480	62415	69350
20	7300	14600	21900	29200	36500	43800	51100	58400	65700	73000
21	7665	15330	22995	30660	38325	45990	53655	61320	68985	76650
22	8030	16060	24090	32120	40150	48180	56210	64240	72270	80300
23	8395	16790	25185	33580	41975	50370	58765	67160	75555	83950
24	8760	17520	26280	35040	43800	52560	61320	70080	78840	87600
25	9125	18250	27375	36500	45625	54750	63875	73000	82125	91250
26	9490	18980	28470	37960	47450	56940	66430	75920	85410	94900
27	9855	19710	29565	39420	49275	59130	68985	78840	88695	98550
28	10220	20440	30660	40880	51100	61320	71540	81760	91980	102200
29	10585	21170	31755	42340	52925	63510	74095	84680	95265	105850

8. Component part list

	Note!
	Ropox will make parts list and circuit diagrams available for extraordinary maintenance and repair beyond what is described in this manual. Repair beyond what is described in this manual may only be done by Ropox designated service personnel.

8.1 Spare parts

Position	Description	Number in product	Item no.
1	Battery	1	25*29030-002
2	Control box	1	25*29530-001
3	Lifting motor	1	25-20235-9
4	Hand control unit	1	25-29050-9
5	Leg spreading motor	1	25-20212-9
6	Brake wheels	2	25-98202-9
7	Wheels	2	25*98212-002

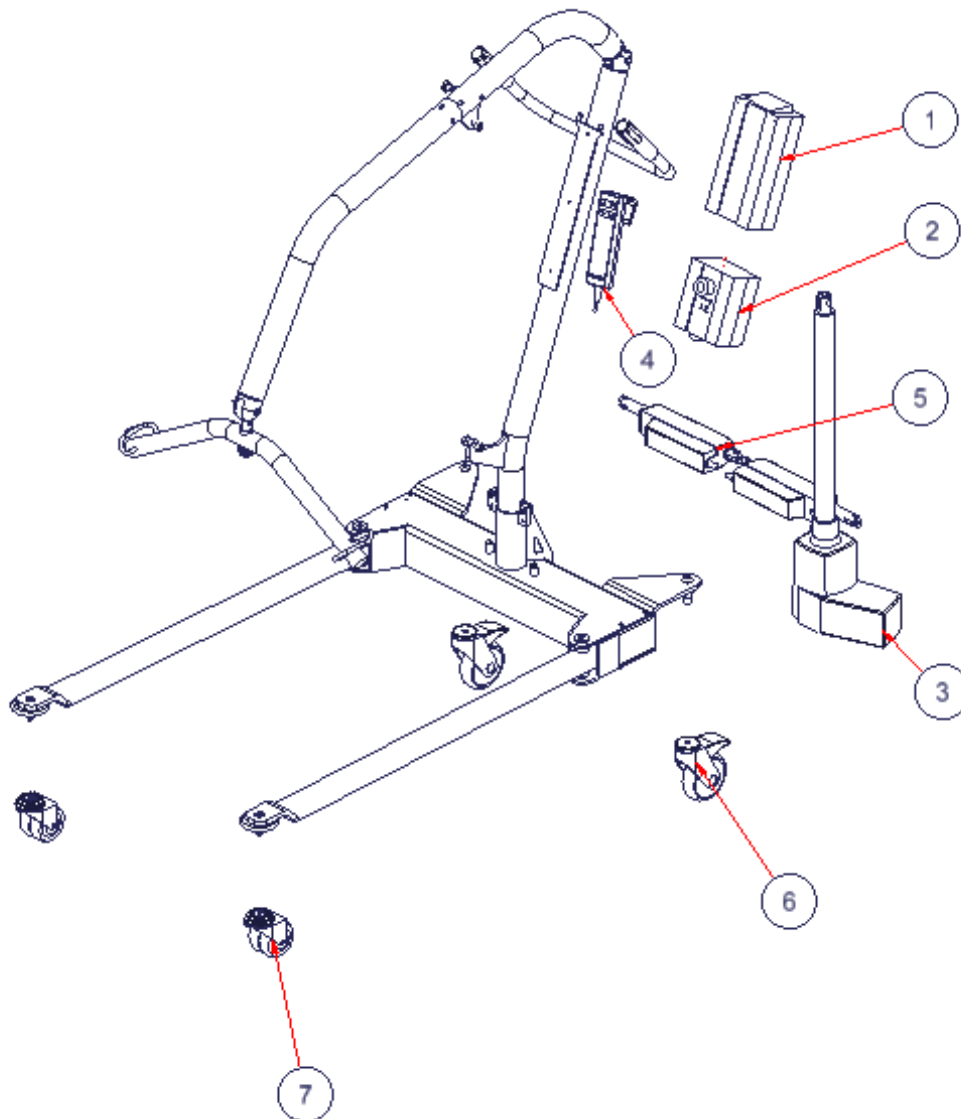

9. Environmental protection

The product is not intended to be disposed as municipal waste. Proper disassembly, sorting and disposal of components must be done by waste disposal professionals.



Part	Disposal recommendation
Control box	Electronics
Motors	Electronics
Handcontrol unit	Electronics
Battery	Electronics
Handle	Hard plastic
Frame	Steel waste
Wheel	Hard plastic

10. Electromagnetic compatibility

10.1 Suitable Environments

The device is suitable for use at home, at daycare centers, at day centers for persons with physical or mental disabilities or at hospitals except near active HF surgical equipment and the RF shielded room of a medical electrical system for magnetic resonance imaging, where the intensity of electromagnetic disturbances is high.

10.2 Cables

Cable component	Length
Hand control spiral cable	2.4m extended.



Warning!

Use of accessories, transducers and cables other than those specified or provided by the manufacturer of this could result in increased electromagnetic emissions or decreased electromagnetic immunity of this equipment and result in improper operation.

10.3 RF portable equipment



Warning!

Portable RF communications equipment (including peripherals such as antenna cables and external antennas) should be used no closer than 30 cm (12 inches) to any part of the device, including cables specified by the manufacturer. Otherwise, degradation of the performance of this equipment could result.

11. Complaints

See our general terms of sale and delivery on www.ropox.com



ROPOX A/S

Ringstedgade 221
DK – 4700 Næstved

Tel.: +45 55 75 05 00 Fax.: +45 55 75 05 50

E-mail: info@ropox.dk

www.ropox.dk